



EAGLEVILLE CITY COUNCIL REGULAR MEETING AGENDA

Eagleville City Hall
Thursday, March 26, 2026

108 South Main Street
7:00 p.m.

Immediately Following Public Hearing

Prior to meeting, please silence all electronic devices.

- 1) **MAYORS WELCOME and CALL TO ORDER** – Mayor Chad Leeman
- 2) **ROLL CALL** – City Recorder Christina Rivas
- 3) **INVOCATION/PLEDGE OF ALLEGIANCE**
- 4) **ADOPTION OF THE AGENDA**
- 5) **CITIZENS' INPUT** - *Any Citizen shall be given up to three (3) minutes to address City Council on any issue. When the Mayor asks, please raise your hand if you wish to speak.*
- 6) **ADOPTION OF THE CONSENT AGENDA**
 - a. Approval of Minutes:
 - i) Work Session – February 12, 2026
 - ii) Regular Meeting – February 26, 2026
 - b. Financial Report – February 2026
- 7) **MAYOR AND COUNCIL PRESENTATIONS**
- 8) **DEPARTMENT REPORTS**
 - City Recorder
 - Fire Department
 - Management Consultant's Report
 - Parks Department
 - Police Department
- 9) **CITY MANAGER REPORT**
- 10) **OLD BUSINESS**

- a. Approve or Deny Ordinance 2026-003 An Ordinance Amending TITLE 16, SECTION 16-112 of the EAGLEVILLE MUNICIPAL CODE: STREET ACCEPTANCE POLICY. (Second Reading)
- b. Accept or Deny the Plan of Services Progress Report for D742 West Webb Road/Map141 Parcel 00100 Annexed February 24, 2022.

11) NEW BUSINESS

- a. Approve or Deny Brendan Tomlinson's Proposal to Construct Fitness Stations at Ronnie Hill Memorial Park for His Eagle Scout Project.
- b. Approve or Deny Referral of Resolution 2026-005 with Attachment A; Petition and Plan of Services for Annexation of Parcel 120 02300 (Moore Property) to the Planning Commission.
- c. Approve or Deny Ordinance 2026-001 Assigning Zoning Classifications and Criteria for Property Under Consideration for Annexation; Parcel 120 04600 (Salem Creek Property) (First Reading)

12) MAYOR'S AND COUNCIL'S CLOSING REMARKS

13) ADJOURNMENT

Item 6a

Approval of Minutes:

- Work Session – February 12, 2026
- Regular Meeting – February 26, 2026

**Minutes of the
City Council Work Session
Eagleville City Hall, Eagleville, TN
Thursday, February 12, 2026– 7:00 PM**

1) MAYORS WELCOME and CALL TO ORDER

Mayor Chad Leeman called the meeting to order at 7:16 p.m.

2) ROLL CALL

The roll was called by City Recorder Christina Rivas.

PRESENT:

Mayor Chad Leeman
Vice Mayor William Tollett
Councilman Ryan Edwards
Councilman Brandon Emamalie
Councilman Chris Hendrix

ABSENT:

Councilman Jason Blair
Councilman Craig Campbell

STAFF:

City Manager Hellyn Riggins
City Recorder Christina Rivas
Police Chief David Breniser

Fire Chief Jonathan Armstrong
Firefighter Chad Carson

GUEST:

Charlie Waite

3) DISCUSSION – There was no discussion.

4) NEW BUSINESS

a) Review Planning Commission’s recommendations for the Former Scales Property Annexation and Resolution 2026-002 Proposed Annexation by Owner Consent

City Manager Hellyn Riggins stated that the Planning Commission reviewed the petition for annexation and recommended that Council consider the request.

Ms. Riggins introduced Mr. Charlie Waite of Salem Creek Partnership, representing the petitioner.

Mr. Waite stated that Stephenson Farms and the annexation of this parcel are tied together. He noted that this parcel was purchased as additional access to the Septic Tank Effluent Pumping (STEP) system via College Grove Road; however, construction has been delayed due to the lack of water supply and pressure.

Mr. Waite explained that Salem Creek Partnership has sufficient water supply for the first 178 lots accessed from Webb Road. He stated that their intention for this particular parcel is to create estate sized lots. He noted that with the delay in development for the Winterbrooke subdivision (on College Grove Road), this property is beneficial, as it will enable them to build a

maintenance road to access the STEP system. He explained that until a 12" water line is built along Highway 41, north of the Harpeth River, residential building will not commence.

Mr. Waite stated that the focus for this property is to develop the first 30 units of Phase I, for which they have the water capacity necessary. He explained that the purpose for their petition for annexation was to participate with other developers for the expansion of the water line and for access road to maintain the STEP system. He noted that the City of Eagleville will not have properties served by an Eagleville STEP system that are not within city limits.

Mr. Waite stated that with the STEP filters installed, he is confident that they can begin developing the property. He expressed his gratitude to Council for their consideration to annex this property and hopes to have lots ready by late spring.

Ms. Riggins stated that the working relationship with Mr. Waite has gone well. She noted that Salem Creek Partnership would bring 97 acres into the City as Planned Residential Development 1 (PRD-1). She emphasized that Salem Creek Partnership has been forthright in their desire to potentially add commercial zoning to this property in future. Ms. Riggins noted that Mr. Waite is exhibiting good faith bringing the whole property into the City at this time, even though they may wish to consider additional zoning classification at a later date.

Mayor Leeman stated that when issues have risen in the past, Salem Creek Partnership has been quick to respond. Mr. Waite encouraged Council to notify him any time to address concerns.

Ms. Riggins expressed her disappointment that the water line expansion has not moved forward. She stated that another petition for annexation has been submitted and, if approved, could help propel this issue forward.

Mr. Waite stated that, initially, they were working with Consolidate Utility District (CUD), but they withdrew their participation from the project. He noted that he is willing to work with the new petitioner for annexation.

Ms. Riggins suggested that Mr. Waite may want to stay to hear Item 4e on tonight's agenda.

Item 4e was moved ahead of Item 4b.

- e) Review of Plan of Services Progress Report for D742 West Webb Road/Map141 Parcel 00100 annexed February 24, 2022.**

City Manager Hellyn Riggins informed Council that the property on Webb Road was annexed in 2022 and that a progress report will be presented at a public hearing in March. She noted that the City provides this property the same services that it provides to all citizens and businesses of Eagleville.

- b) Review Ordinance 2026-001 Assigning Zoning Classification and Criteria for Property to be Annexed Known as Parcel 120 04600**

City Manager Hellyn Riggins stated that the first reading for this item will be in March. She requested that Council read the Ordinance and provide her with input or concerns so that she may address them prior to the public hearing.

- c) Review Ordinance 2026-003 An Ordinance Amending TITLE 16, SECTION 16-112 of the EAGLEVILLE MUNICIPAL CODE: STREET ACCEPTANCE POLICY**

City Manager Hellyn Riggins informed Council that this ordinance is also agendized for the public

hearing in March. She noted that this ordinance will complement a Speed Limit ordinance that will be brought before Council in March and April 2026.

d) Discussion to Review Guidelines for Recreational Vehicles (Requested by Citizen)

City Manager Hellyn Riggins stated that a citizen requested to have zoning regulations for recreational vehicles such as campers and motor homes. She explained that she will have the item on February's Regular Meeting agenda to take formal action and send the item to the Planning Commission for a report and guidelines.

Ms. Riggins noted that there was no documentation on record at this time regarding where campers are parked.

f) Set Yearly Retreat Date

City Manager Hellyn Riggins stated that yearly retreats are essential for setting priorities, goals and achievements and provides direction for the City. She stated that she is open to any time that the Council is available to meet.

Mayor Leeman stated that he would not be available on March 14, 15 and 22 and noted that spring break begins on March 28.

Council Member Brandon Emamalie stated that he would be able to attend in the morning.

Vice Mayor William Tollett concurred with mornings.

Council Member Ryan Edwards stated that any Saturday will work with his schedule.

Ms. Riggins stated that she will put it to a vote at the next meeting and that the choices are between March 7 and March 21.

5) ADJOURNMENT

Fire Chief Jonathan Armstrong introduced newly hired firefighter Chad Carson who came from Middle Tennessee State University (MTSU), where he was an Assistant Fire Marshal. He noted that prior to that, he worked for the Spring Hill Fire Department.

Mr. Carson expressed his appreciation for being part of the Eagleville team.

Chief Armstrong emphasized that Mr. Carson brings experience as a fire marshal, fire inspector and as a trainer.

Mr. Carson stated that Eagleville reminds him of Spring Hill in the 1990's; watching the city grow from a population of 8,000 to 40,000. He stated that he is excited to be here and to be able to watch the City grow.

Vice Mayor Tollett commended staff's efforts during the ice storm. He noted that he heard a lot of positive comments regarding the good work that was performed by the City.

City Manager Hellyn Riggins noted that several meetings were held to prepare for the event.

Mayor Leeman stated that he attended a ceremony in Rutherford County, which declared a proclamation in support of law enforcement, honoring police chiefs.

Mayor Leeman confirmed there was no further business and adjourned the meeting at 7:50 p.m.

Approved by:

Mayor Chad Leeman

Submitted by:

City Recorder Christina Rivas

Date minutes approved: _____

**Minutes of the
City Council Regular Meeting
Eagleville City Hall, Eagleville, TN
Thursday, February 26, 2026**

1) MAYORS WELCOME and CALL TO ORDER

Mayor Chad Leeman called the meeting to order at 7:00 p.m.

2) ROLL CALL

The roll was called by City Recorder Christina Rivas.

PRESENT:

Mayor Chad Leeman
Vice Mayor William Tollett
Councilman Ryan Edwards
Councilman Chris Hendrix

ABSENT:

Councilman Jason Blair
Councilman Craig Campbell
Councilman Brandon Emamalie

STAFF:

City Manager Hellyn Riggins
City Recorder Christina Rivas
Fire Chief Jonathan Armstrong

City Attorney Stephen Aymett
Police Chief David Breniser

3) INVOCATION/PLEDGE OF ALLEGIANCE

Mayor Leeman gave the Invocation.
Council Member Chris Hendrix led the Pledge of Allegiance.

4) ADOPTION OF THE AGENDA

Vice Mayor William Tollett moved to adopt the Agenda.
Council Member Chris Hendrix seconded the motion.
The **MOTION** passed 4-0.

5) CITIZENS' INPUT – There were no speakers.

6) ADOPTION OF THE CONSENT AGENDA

Vice Mayor Tollett moved to adopt the Consent Agenda.
Council Member Hendrix seconded the motion.
The **MOTION** passed 4-0.

7) MAYOR AND COUNCIL PRESENTATIONS – There were no presentations.

8) DEPARTMENT REPORTS - Mayor Leeman noted that Department Reports were in the packet.

City Recorder

City Recorder Christina Rivas announced that staff will no longer send out requests asking Council Members whether they will attend Council Meetings. She stated that staff will anticipate that Council will attend unless they inform staff to the contrary, ahead of the meeting.

Fire Department

Financial Consultant's Report

Parks Department

Police Department

9) CITY MANAGER REPORT - Mayor Leeman noted that Department Reports were in the packet.

10) OLD BUSINESS

- a. **Approve or Deny Acceptance of the Planning Commission's Recommendation to Proceed with Exploring the Annexation.**

City Manager Hellyn Riggins stated that the Planning Commission recommended to proceed with the annexation.

Council Member Ryan Edwards moved to approve the item.

Council Member Hendrix seconded the motion.

The **MOTION** passed 4-0.

11) NEW BUSINESS

- a. **Approve or Deny Resolution 2026-001 Calling for a Public Hearing for the Annexation of Parcel #120-46.00-000 with Its Plan of Services (Resolution 2026-002).**

Vice Mayor Tollett moved to approve the item.

Council Member Hendrix seconded the motion.

The **MOTION** passed 4-0.

- b. **Approve or Deny Ordinance 2026-003 An Ordinance Amending TITLE 16, SECTION 16-112 of the EAGLEVILLE MUNICIPAL CODE: STREET ACCEPTANCE POLICY. (First Reading)**

Vice Mayor Tollett moved to approve the item.

Council Member Edwards seconded the motion.

The **MOTION** passed 4-0.

- c. **Vote to Declare Date for Council Retreat – Saturday, March 7 or Saturday, March 21, 2026, at 8:30 a.m. at City Hall.**

Vice Mayor Tollett moved to declare the date of Saturday, March 21, 2026 at 8:30 a.m. at City Hall for the Council Retreat.

Council Member Hendrix seconded the motion.

The **MOTION** passed 4-0.

- d. **Approve or Deny Referral of Review of Zoning Regulations Regarding Recreational Vehicles to the Planning Commission for a Report and Recommendation of Guidelines.**

Council Member Edwards moved to approve the item.

Vice Mayor Tollett seconded the motion.

The **MOTION** passed 4-0.

12) MAYOR'S AND COUNCIL'S CLOSING REMARKS

13) ADJOURNMENT

Mayor Leeman confirmed there was no further business and adjourned the meeting at 7:06 p.m.

Approved by:

Mayor Chad Leeman

Submitted by:

City Recorder Christina Rivas

Date minutes approved: _____

Item 6b Financial Report – February 2026

CITY OF EAGLEVILLE, TENNESSEE
FOR THE MONTH ENDED FEBRUARY 28, 2026



Waycaster, CPA LLC

To the City Council
City of Eagleville, Tennessee

Please accept this letter as a summary of the City's activity for the month ended February 28, 2026.

- The General Fund had \$2,573,104 in cash at February 28th; an increase from the prior month of \$111,216. The Fund reports a monthly profit of \$74,053 with a year-to-date profit of \$416,540. State sales tax for the month totaled \$7,742 and local option sales tax for the month totaled \$82,619. Property tax collections totaled \$46,828 for current year receipts.
- The overall revenues of the General Fund were \$116,586, while total expenditures were \$93,533.
- The overall budgeted revenues are \$1,901,870; \$1,519,231 of this has been collected – this represents 79.88%. The overall budgeted expenditures (excluding transfers) are \$1,647,214; \$975,692 of this has been expended – this represents 59.23%.
- Below is a table detailing the fund balance of the General Fund as of February 28, 2026:

General Fund

Fund Balance - Beginning	\$ 2,317,165.00
Add: Revenues	\$ 1,519,231.00
Less: Expenses	<u>\$ (1,102,692.00)</u>
Fund Balance - Ending	\$ 2,733,704.00
Recommended Minimum Balance	\$ 1,500,000.00
Excess Fund Balance	\$ 1,233,704.00

- At month-end, the State Street Aid Fund had a cash balance of \$345,109 a decrease of \$792 from the prior month. Interest earnings totaled \$958. The fund has a monthly loss of \$24, with a year-to-date profit of \$15,629.
- The Debt service fund currently has \$273,238 cash available. Interest earnings totaled \$633. The fund reports a profit of \$6,214, with a year-to-date loss of \$174,130. USDA refunded us as shown.
- The Capital Projects Fund has \$307,714 at month-end. The fund reports a profit of \$631, with a year-to-date loss of \$109,130. Capital outlay thus far totals \$116,108.
- The Sewer Fund had \$817,027 as of February 28th. This is an increase of \$10,829 from the prior month. February reports an operating profit of \$2,037 with a net profit of \$678. The year-to-date operating profit is \$36,426 with a year-to-date profit of \$27,946. As a reminder, this includes depreciation expense totaling \$57,670 thus far, which is a non-cash expenditure. Interest earned totaled \$1,745.
- The Developmental Impact fund has \$15,611 at month-end. The restrictions for various City functions are presented page 30. The Fund reports a profit of \$21, with a year-to-date profit of \$15,611.

Thank you,
Cassie Edrington, MPA

Waycaster, CPA LLC

To the City Council
City of Eagleville, Tennessee
Eagleville, Tennessee

The accompanying financial statements of the City of Eagleville, Tennessee as of February 28, 2026 and for the eight months ended were not subjected to an audit, review, or compilation engagement by us and we do not express an opinion, a conclusion, nor provide any assurance on them.

March 20, 2026

City of Eagleville
Balance Sheet
 As of February 28, 2026

	Feb 28, 26
ASSETS	
Current Assets	
Checking/Savings	
105 - Volunteer Bank GF	651,793.82
Apex Bank - CD	200,000.00
LGIP - General Fund	1,543,582.44
100 · Petty Cash	250.00
104 · US Bank Checking	150,460.74
116 · Apex Bank - General Fund	27,016.73
Total Checking/Savings	2,573,103.73
Other Current Assets	
122 - State/Local Taxes Recv.	97,037.10
126 - Prop. Taxes Rec-Curr Yr	221,831.24
AFDA Property Taxes	-3,496.41
Due from Capital Projects Fund	49,711.91
Due from Debt Service Fund	-20.00
124 · Lease Receivable	48,795.34
125 · Lease Receivable - Interest	357.70
135 · Due from Sewer Fund	40,037.33
Total Other Current Assets	454,254.21
Total Current Assets	3,027,357.94
TOTAL ASSETS	3,027,357.94
LIABILITIES & EQUITY	
Liabilities	
Current Liabilities	
Other Current Liabilities	
215 - Due to Street Aid Fund	496.39
221 - Payroll Liabilities	-2,300.72
230 - Deferred Property Tax Rev	218,334.83
256 - Due to Comcast - Bond	35,020.22
233 · Lease Deferred Inflow	41,822.43
239 · Due to State - Litigation Tax	270.89
243 · E-Ticketing	8.91
Total Other Current Liabilities	293,652.95
Total Current Liabilities	293,652.95
Total Liabilities	293,652.95
Equity	
350 - Fund Balance	2,317,165.38
Net Income	416,539.61
Total Equity	2,733,704.99
TOTAL LIABILITIES & EQUITY	3,027,357.94

City of Eagleville
Profit & Loss
February 2026

	<u>Feb 26</u>	<u>Jul '25 - Feb 26</u>
Income		
Fines & Fees		
32615 · Planning Dept. Fees	0.00	500.00
32616 · CC Processing Fees	18.69	392.57
35110 · City Court Fines & Costs	2,076.79	39,516.98
35140 · Drug Fees	0.00	118.75
Total Fines & Fees	<u>2,095.48</u>	<u>40,528.30</u>
Fire Dept. Income		
34260 · Fire Dept Donations	0.00	600.00
Total Fire Dept. Income	<u>0.00</u>	<u>600.00</u>
Interest Income		
36100 · Interest Gen. Fund Svgs	5,738.66	45,374.84
36101 · Interest Income - CD	0.00	328.78
Total Interest Income	<u>5,738.66</u>	<u>45,703.62</u>
Intergovernmental Revenue		
33102 · Ruth. Co Fire Dept Grant	0.00	90,000.00
33103 · State of TN Grant	0.00	3,000.00
33320 · TVA n Lieu of Tax	0.00	5,473.92
33500 · State of TN-Telecomm.STG	55.14	465.10
33510 · State of TN-Sales Tax	7,741.54	70,100.36
33530 · State of TN-Beer Tax	0.00	176.66
33552 · St of TN-Cty St/Trans	123.10	904.32
33558 · State Trans. & Modernization	41.19	386.55
33593 · Excise Tax	1,522.72	1,522.72
33700 · State of TN Sport Betting	0.00	1,408.25
Total Intergovernmental Revenue	<u>9,483.69</u>	<u>173,437.88</u>
License & Permits		
32600 · Business License	0.00	80.00
32610 · Building Permits	1,898.00	14,064.50
32620 · Beer Permits	0.00	300.00
Total License & Permits	<u>1,898.00</u>	<u>14,444.50</u>
Local Taxes		
31100 · Property Tax	46,828.41	183,566.00
31200 · Property Taxes-Pr. Years	179.00	6,584.99
31300 · Tax Penalty & Interest	32.14	605.33
31600 · Rutherford Co Sales Tax	82,619.25	910,830.54
31800 · Business Taxes	21.00	12,507.17
31980 · Liquor by Drink Tax	2,837.50	25,878.69
31990 · Local Beer Tax	3,187.91	26,157.44
Total Local Taxes	<u>135,705.21</u>	<u>1,166,130.16</u>
Misc. Revenues		
34621 - Donations Police	0.00	500.00
36211 - Rent - House	1,650.00	13,200.00
36000 · Misc. Income	0.00	43.01

City of Eagleville
Profit & Loss
February 2026

	<u>Feb 26</u>	<u>Jul '25 - Feb 26</u>
36200 · Chamber of Commerce Rent	500.00	3,500.00
36210 · Rental Income	4,045.01	28,713.92
36240 · Dividends & Reimbursements	0.00	7,310.00
Total Misc. Revenues	<u>6,195.01</u>	<u>53,266.93</u>
Parks & Recreation Revenue		
34724 · Ballpark Fence Banners	3,000.00	3,000.00
34726 · Ball Sign-up Fees	3,420.00	3,420.00
34727 · Pavilion & Field Rent	50.00	2,125.00
34728 · Booth Fees	0.00	5,825.00
34729 · Event Sponsorships	0.00	10,750.00
Total Parks & Recreation Revenue	<u>6,470.00</u>	<u>25,120.00</u>
Total Income	<u>167,586.05</u>	<u>1,519,231.39</u>
Gross Profit	167,586.05	1,519,231.39

City of Eagleville
Profit & Loss
February 2026

Expense	Feb 26	Jul '25 - Feb 26
41000 · General Gov.		
111 - City Recorder	4,403.20	35,213.81
112 - Overtime Pay	0.00	817.90
113 - City Manager	7,776.46	62,190.66
114- Salaries -City Clerk	4,328.00	34,612.71
140 - Retirement	1,226.52	10,453.70
141 - Payroll Taxes	1,211.71	9,797.03
142 - Insurance	2,025.00	15,336.00
146 - Workman's Comp	0.00	390.37
211 - Postage	0.00	484.22
230 - Dues	180.00	1,830.48
231 - Legal Notices / Ads	0.00	346.44
241 - Electricity	421.31	3,735.93
242 - Water	16.61	170.03
244 - Natural Gas	572.92	979.99
245 - Telephone & Internet	355.87	2,695.33
250 - Professional Services	0.00	18,000.00
251 - City Judge Fee	0.00	1,050.00
252 - Attorney Fees	1,990.00	12,870.00
253 - Accounting Fees	1,671.00	18,916.00
254 - Engineering	1,211.00	7,729.00
256 - Audit Fees	0.00	6,500.00
257 - Planning / Zoning	0.00	18.24
258 - House - Lease Expenses	515.00	2,015.00
261 - Repair & Maint Vehicle	0.00	2,570.48
280 - Staff - day trips	0.00	139.95
295 - Trash pickup	274.01	922.14
299 - Miscellaneous	212.43	219.42
310 - Office Supplies	202.04	1,919.30
320 - Parts & Supplies - Vehicl	0.00	1,338.20
331 - Fuel - Vehicle	103.82	674.09
454 - Sewer	227.96	1,593.48
471 - Economic Development	0.00	7,400.00
510 - Insurance/ Bonds	0.00	20,423.35
531 - Copier Lease / New Equip.	306.08	2,552.92
534 - Cleaning/Janitorial	75.00	1,889.25
535 - Facility & Grounds R&M	280.38	1,057.28
536 - Parts/Supplies	0.00	394.06
538 - Library Grant	0.00	38,258.25
539- Building Inspections	425.00	2,890.00
548 - Mayor's Discretionary Acc	0.00	289.94
556 - Bank Fees - Other	166.87	1,076.75
562 - Tech - Annual Maint	0.00	12,621.96

City of Eagleville
Profit & Loss
February 2026

	<u>Feb 26</u>	<u>Jul '25 - Feb 26</u>
565 - Beautification	0.00	3,127.00
540 - Schools - Liquor Tax Pass Thru	1,585.73	11,520.59
546 - 546 - Staff Mtgs/Confer	0.00	120.00
564 - Storage	75.00	600.00
568 - Property Tax Fees	0.00	2,779.00
Total 41000 - General Gov.	31,838.92	362,530.25

City of Eagleville
Profit & Loss
February 2026

Expense	Feb 26	Jul '25 - Feb 26
42100 · Police Dept.		
111 - Salaries - Police Chief	6,066.76	48,515.02
113 - Hourly Pay	12,286.40	99,086.26
140 - Retirement	1,363.64	11,801.82
141 - Payroll Taxes	1,283.33	10,644.33
142 - Insurance	2,699.97	20,447.94
146 - Workman's Comp	0.00	9,396.75
241 - Electricity	166.63	1,406.99
242- Water	16.33	112.44
244 - Natural Gas	183.34	286.66
245 - Telephone & Internet	397.04	2,779.28
261 - Vehicle Expense	54.23	1,558.60
266 - Facility Repair & Maint	149.00	875.86
295 - Trash Pickup	13.50	193.00
299 - Miscellaneous	0.00	36.05
300 - Supplies	25.17	344.67
301 - Cell phones & Air Cards	472.91	1,927.69
312 - Equipment	0.00	1,380.55
326 - Clothing	0.00	80.00
331 - Vehicle Fuel	757.70	4,259.36
510 - Insurance	0.00	24,299.97
562 - Tech - Annual Maint	0.00	3,694.84
780 - State Salary Supplement	0.00	3,000.00
Total 42100 · Police Dept.	25,935.95	246,128.08

City of Eagleville
Profit & Loss
February 2026

Expense	Feb 26	Jul '25 - Feb 26
42200 · Fire Dept.		
111 - Salaries - Fire Chief	5,977.76	47,800.40
113 - Salaries - Fire Hourly	8,825.72	87,956.54
140 - Retirement	1,099.89	10,718.70
141 - Payroll Taxes	1,108.85	10,326.27
142 - Insurance	2,025.00	11,587.10
146 - Workman's Comp	0.00	6,685.99
148 - Training	0.00	2,241.95
162 - Incentive Program	2,000.00	8,306.00
230 - Dues	0.00	1,091.55
231 - Advertising / Promotion	0.00	222.50
241 - Electricity	812.89	5,182.06
242 - Water	47.60	306.79
244 - Natural Gas	558.08	923.72
245 - Telephone & Internet	139.96	2,809.05
261 - R & M - Veh & Equip	150.06	6,989.21
266 - Facility R & M	458.00	668.97
280 - Travel	0.00	710.65
295 - Trash pickup	13.51	193.03
300 - Fire Dept Supplies/ Misc.	603.85	1,853.94
320 - Parts & Supplies - Truck	-1.49	82.06
326 - Uniform/Clothing	0.00	857.00
331 - Fire Dept. Fuel	1,108.44	4,263.56
510 - Insurance	0.00	35,720.90
562 - Tech - Annual Maint	0.00	8,074.93
624 - On Truck Equip	0.00	16,840.37
720 - Discretionary (Donation)	0.00	1,070.03
Total 42200 · Fire Dept.	24,928.12	273,483.27

City of Eagleville
Profit & Loss
February 2026

	<u>Feb 26</u>	<u>Jul '25 - Feb 26</u>
44400 · Parks & Recreation		
111 - Salary -Park/Maint Super,	3,801.60	30,403.76
140 - Retirement	282.46	2,393.52
141 - Payroll Taxes	276.78	2,225.59
142 - Insurance	675.00	5,112.00
146 - Workman's Comp	0.00	1,005.89
241 - Electricity	571.26	2,720.59
242 - Water	18.17	141.97
245 - Phone	105.38	567.32
250 - Professional Services	2,833.34	10,000.00
254 - Mowing	0.00	0.00
260 - Maintenance	1,054.51	7,563.16
295 - Trash pickup	75.00	600.00
299 - Misc.	0.00	173.94
300 - Supplies	472.72	697.27
312 - Equipment	654.19	1,018.83
320 - Concession Stand	9.48	9.48
331 - Fuel	0.00	749.07
510 - Insurance	0.00	5,855.17
562 - Tech - Annual Maint	0.00	175.94
583 - Fall Festival	0.00	14,465.21
584 - Christmas Events	0.00	6,171.47
585 - Summer Events	0.00	1,500.00
Total 44400 · Parks & Recreation	<u>10,829.89</u>	<u>93,550.18</u>

City of Eagleville
Profit & Loss
February 2026

	<u>Feb 26</u>	<u>Jul '25 - Feb 26</u>
Expense		
51000 · Other Financing Use		
51621 - Transfer to Street Aid	0.00	25,000.00
51630 - Transfer to Debt Servic	0.00	102,000.00
Total 51000 · Other Financing Use	<u>0.00</u>	<u>127,000.00</u>
Total Expense	<u>93,532.88</u>	<u>1,102,691.78</u>
Net Income	<u><u>74,053.17</u></u>	<u><u>416,539.61</u></u>

City of Eagleville

Profit & Loss Budget vs. Actual

July 2025 through February 2026

	Jul '25 - Feb 26	Budget	\$ Over Budget	% of Budget
Income				
Fines & Fees				
32615 · Planning Dept. Fees	500.00	900.00	-400.00	55.56%
32616 · CC Processing Fees	392.57	1,600.00	-1,207.43	24.54%
35110 · City Court Fines & Costs	39,516.98	46,000.00	-6,483.02	85.91%
35140 · Drug Fees	118.75			
Total Fines & Fees	40,528.30	48,500.00	-7,971.70	83.56%
Fire Dept. Income				
34260 · Fire Dept Donations	600.00	1,000.00	-400.00	60.0%
Total Fire Dept. Income	600.00	1,000.00	-400.00	60.0%
Interest Income				
36100 · Interest Gen. Fund Svgs	45,374.84	40,000.00	5,374.84	113.44%
36101 · Interest Income - CD	328.78	11,000.00	-10,671.22	2.99%
Total Interest Income	45,703.62	51,000.00	-5,296.38	89.62%
Intergovernmental Revenue				
33100 · Police Salary Supplement	0.00	3,200.00	-3,200.00	0.0%
33101 · TSHO Grant	0.00	4,000.00	-4,000.00	0.0%
33102 · Ruth. Co Fire Dept Grant	90,000.00	80,000.00	10,000.00	112.5%
33103 · State of TN Grant	3,000.00			
33320 · TVA n Lieu of Tax	5,473.92	9,900.00	-4,426.08	55.29%
33500 · State of TN-Telecomm.STG	465.10	725.00	-259.90	64.15%
33510 · State of TN-Sales Tax	70,100.36	100,500.00	-30,399.64	69.75%
33530 · State of TN-Beer Tax	176.66	360.00	-183.34	49.07%
33552 · St of TN-Cty St/Trans	904.32	1,400.00	-495.68	64.59%
33558 · State Trans. & Modernization	386.55	275.00	111.55	140.56%
33593 · Excise Tax	1,522.72	1,400.00	122.72	108.77%
33700 · State of TN Sport Betting	1,408.25	1,500.00	-91.75	93.88%
Total Intergovernmental Revenue	173,437.88	203,260.00	-29,822.12	85.33%
License & Permits				
32600 · Business License	80.00	100.00	-20.00	80.0%
32610 · Building Permits	14,064.50	42,000.00	-27,935.50	33.49%
32620 · Beer Permits	300.00	200.00	100.00	150.0%
Total License & Permits	14,444.50	42,300.00	-27,855.50	34.15%
Local Taxes				
31100 · Property Tax	183,566.00	201,235.00	-17,669.00	91.22%
31200 · Property Taxes-Pr. Years	6,584.99	6,200.00	384.99	106.21%
31300 · Tax Penalty & Interest	605.33	500.00	105.33	121.07%
31600 · Rutherford Co Sales Tax	910,830.54	1,112,000.00	-201,169.46	81.91%
31800 · Business Taxes	12,507.17	65,000.00	-52,492.83	19.24%
31980 · Liquor by Drink Tax	25,878.69	35,000.00	-9,121.31	73.94%
31990 · Local Beer Tax	26,157.44	39,000.00	-12,842.56	67.07%
Total Local Taxes	1,166,130.16	1,458,935.00	-292,804.84	79.93%
Misc. Revenues				
34621 - Donations Police	500.00	1,000.00	-500.00	50.0%

City of Eagleville
Profit & Loss Budget vs. Actual
 July 2025 through February 2026

	<u>Jul '25 - Feb 26</u>	<u>Budget</u>	<u>\$ Over Budget</u>	<u>% of Budget</u>
36211 - Rent - House	13,200.00	18,150.00	-4,950.00	72.73%
36000 - Misc. Income	43.01	2,500.00	-2,456.99	1.72%
36200 - Chamber of Commerce Rent	3,500.00	6,000.00	-2,500.00	58.33%
36210 - Rental Income	28,713.92	40,000.00	-11,286.08	71.79%
36240 - Dividends & Reimbursements	7,310.00	6,000.00	1,310.00	121.83%
Total Misc. Revenues	<u>53,266.93</u>	<u>73,650.00</u>	<u>-20,383.07</u>	<u>72.32%</u>
Parks & Recreation Revenue				
34724 - Ballpark Fence Banners	3,000.00	3,000.00	0.00	100.0%
34725 - Conc. Stand Income	0.00	1,000.00	-1,000.00	0.0%
34726 - Ball Sign-up Fees	3,420.00	2,500.00	920.00	136.8%
34727 - Pavilion & Field Rent	2,125.00	125.00	2,000.00	1,700.0%
34728 - Booth Fees	5,825.00	4,900.00	925.00	118.88%
34729 - Event Sponsorships	10,750.00	11,700.00	-950.00	91.88%
Total Parks & Recreation Revenue	<u>25,120.00</u>	<u>23,225.00</u>	<u>1,895.00</u>	<u>108.16%</u>
Total Income	<u>1,519,231.39</u>	<u>1,901,870.00</u>	<u>-382,638.61</u>	<u>79.88%</u>
Gross Profit	<u>1,519,231.39</u>	<u>1,901,870.00</u>	<u>-382,638.61</u>	<u>79.88%</u>

City of Eagleville
Profit & Loss Budget vs. Actual
July 2025 through February 2026

Expense	Jul '25 - Feb 26	Budget	\$ Over Budget	% of Budget
41000 - General Gov.				
111 - City Recorder	35,213.81	57,251.00	-22,037.19	61.51%
112 - Overtime Pay	817.90	2,651.00	-1,833.10	30.85%
113 - City Manager	62,190.66	101,094.00	-38,903.34	61.52%
114- Salaries -City Clerk	34,612.71	56,260.00	-21,647.29	61.52%
140 - Retirement	10,453.70	16,142.00	-5,688.30	64.76%
141 - Payroll Taxes	9,797.03	16,621.00	-6,823.97	58.94%
142 - Insurance	15,336.00	23,688.00	-8,352.00	64.74%
146 - Workman's Comp	390.37	6,290.00	-5,899.63	6.21%
147 - Unemployment Tax	0.00	300.00	-300.00	0.0%
211 - Postage	484.22	800.00	-315.78	60.53%
230 - Dues	1,830.48	2,100.00	-269.52	87.17%
231 - Legal Notices / Ads	346.44	1,800.00	-1,453.56	19.25%
241 - Electricity	3,735.93	7,000.00	-3,264.07	53.37%
242 - Water	170.03	700.00	-529.97	24.29%
244 - Natural Gas	979.99	3,600.00	-2,620.01	27.22%
245 - Telephone & Internet	2,695.33	3,345.00	-649.67	80.58%
250 - Professional Services	18,000.00	36,000.00	-18,000.00	50.0%
251 - City Judge Fee	1,050.00	1,800.00	-750.00	58.33%
252 - Attorney Fees	12,870.00	26,000.00	-13,130.00	49.5%
253 - Accounting Fees	18,916.00	32,000.00	-13,084.00	59.11%
254 - Engineering	7,729.00	15,000.00	-7,271.00	51.53%
256 - Audit Fees	6,500.00	6,500.00	0.00	100.0%
257 - Planning / Zoning	18.24	4,000.00	-3,981.76	0.46%
258 - House - Lease Expenses	2,015.00	2,000.00	15.00	100.75%
261 - Repair & Maint Vehicle	2,570.48	1,000.00	1,570.48	257.05%
280 - Staff - day trips	139.95	775.00	-635.05	18.06%
281 - Staff - overnight	0.00	500.00	-500.00	0.0%
282 - City Council Travel	0.00	500.00	-500.00	0.0%
283 - Boards & Comm - Travel	0.00	500.00	-500.00	0.0%
295 - Trash pickup	922.14	600.00	322.14	153.69%
299 - Miscellaneous	219.42	2,000.00	-1,780.58	10.97%
301 - Cell Phones & Air Cards	0.00	410.00	-410.00	0.0%
310 - Office Supplies	1,919.30	2,500.00	-580.70	76.77%
320 - Parts & Supplies - Vehicl	1,338.20	1,000.00	338.20	133.82%
331 - Fuel - Vehicle	674.09	1,700.00	-1,025.91	39.65%
415 - Pers. Prop. Audit Costs	0.00	175.00	-175.00	0.0%
454 - Sewer	1,593.48	2,500.00	-906.52	63.74%
471 - Economic Development	7,400.00	7,400.00	0.00	100.0%
510 - Insurance/ Bonds	20,423.35	25,000.00	-4,576.65	81.69%
531 - Copier Lease / New Equip.	2,552.92	3,580.00	-1,027.08	71.31%
534 - Cleaning/Janitorial	1,889.25	2,500.00	-610.75	75.57%
535 - Facility & Grounds R&M	1,057.28	5,000.00	-3,942.72	21.15%

City of Eagleville
Profit & Loss Budget vs. Actual
 July 2025 through February 2026

	<u>Jul '25 - Feb 26</u>	<u>Budget</u>	<u>\$ Over Budget</u>	<u>% of Budget</u>
536 - Parts/Supplies	394.06	600.00	-205.94	65.68%
538 - Library Grant	38,258.25	51,011.00	-12,752.75	75.0%
539- Building Inspections	2,890.00	6,000.00	-3,110.00	48.17%
541 - Re-appraisal Fees	0.00	6,318.00	-6,318.00	0.0%
548 - Mayor's Discretionary Acc	289.94	1,000.00	-710.06	28.99%
555 - Credit Card Fee	0.00	1,600.00	-1,600.00	0.0%
556 - Bank Fees - Other	1,076.75	200.00	876.75	538.38%
562 - Tech - Annual Maint	12,621.96	12,800.00	-178.04	98.61%
563 - Tech - Hardware & Softwar	0.00	250.00	-250.00	0.0%
565 - Beautification	3,127.00	1,000.00	2,127.00	312.7%
540 · Schools - Liquor Tax Pass Thru	11,520.59	17,500.00	-5,979.41	65.83%
546 · 546 - Staff Mtgs/Confer	120.00	500.00	-380.00	24.0%
546b · 546B - City Council Mtgs/Confer	0.00	500.00	-500.00	0.0%
546c · 546C - PC & BZA Mtgs & Conferen	0.00	500.00	-500.00	0.0%
564 · Storage	600.00	1,000.00	-400.00	60.0%
568 · Property Tax Fees	2,779.00	4,850.00	-2,071.00	57.3%
Total 41000 · General Gov.	362,530.25	586,211.00	-223,680.75	61.84%

City of Eagleville
Profit & Loss Budget vs. Actual
July 2025 through February 2026

Expense	Jul '25 - Feb 26	Budget	\$ Over Budget	% of Budget
42100 · Police Dept.				
111 - Salaries - Police Chief	48,515.02	78,868.00	-30,352.98	61.51%
113 - Hourly Pay	99,086.26	165,372.00	-66,285.74	59.92%
140 - Retirement	11,801.82	18,147.00	-6,345.18	65.04%
141 - Payroll Taxes	10,644.33	18,684.00	-8,039.67	56.97%
142 - Insurance	20,447.94	31,584.00	-11,136.06	64.74%
146 - Workman's Comp	9,396.75	6,200.00	3,196.75	151.56%
148 - Police Training	0.00	1,500.00	-1,500.00	0.0%
165 - Drug Fund Expenses	0.00	500.00	-500.00	0.0%
211 - Postage	0.00	25.00	-25.00	0.0%
230 - Dues	0.00	3,000.00	-3,000.00	0.0%
241 - Electricity	1,406.99	1,660.00	-253.01	84.76%
242- Water	112.44	220.00	-107.56	51.11%
244 - Natural Gas	286.66	164.00	122.66	174.79%
245 - Telephone & Internet	2,779.28	4,750.00	-1,970.72	58.51%
261 - Vehicle Expense	1,558.60	10,000.00	-8,441.40	15.59%
266 - Facility Repair & Maint	875.86	500.00	375.86	175.17%
280 - Travel	0.00	1,000.00	-1,000.00	0.0%
295 - Trash Pickup	193.00	320.00	-127.00	60.31%
299 - Miscellaneous	36.05	2,000.00	-1,963.95	1.8%
300 - Supplies	344.67	6,500.00	-6,155.33	5.3%
301 - Cell phones & Air Cards	1,927.69	5,800.00	-3,872.31	33.24%
312 - Equipment	1,380.55	10,000.00	-8,619.45	13.81%
326 - Clothing	80.00	2,000.00	-1,920.00	4.0%
331 - Vehicle Fuel	4,259.36	12,000.00	-7,740.64	35.5%
510 - Insurance	24,299.97	14,000.00	10,299.97	173.57%
562 - Tech - Annual Maint	3,694.84	5,030.00	-1,335.16	73.46%
563 - Tech - Hardware & Softwar	0.00	65.00	-65.00	0.0%
765 - TSHO Grant	0.00	8,000.00	-8,000.00	0.0%
780 - State Salary Supplement	3,000.00	1,600.00	1,400.00	187.5%
Total 42100 · Police Dept.	246,128.08	409,489.00	-163,360.92	60.11%

City of Eagleville
Profit & Loss Budget vs. Actual
July 2025 through February 2026

Expense	Jul '25 - Feb 26	Budget	\$ Over Budget	% of Budget
42200 · Fire Dept.				
111 - Salaries - Fire Chief	47,800.40	77,711.00	-29,910.60	61.51%
113 - Salaries - Fire Hourly	87,956.54	161,603.00	-73,646.46	54.43%
140 - Retirement	10,718.70	17,781.00	-7,062.30	60.28%
141 - Payroll Taxes	10,326.27	18,308.00	-7,981.73	56.4%
142 - Insurance	11,587.10	23,688.00	-12,100.90	48.92%
146 - Workman's Comp	6,685.99	7,700.00	-1,014.01	86.83%
147 -Unemployment Tax	0.00	300.00	-300.00	0.0%
148 - Training	2,241.95	4,250.00	-2,008.05	52.75%
161 - Fire Calls	0.00	2,500.00	-2,500.00	0.0%
162 - Incentive Program	8,306.00	25,000.00	-16,694.00	33.22%
230 - Dues	1,091.55	1,250.00	-158.45	87.32%
231 - Advertising / Promotion	222.50	2,500.00	-2,277.50	8.9%
241 - Electricity	5,182.06	7,850.00	-2,667.94	66.01%
242 - Water	306.79	600.00	-293.21	51.13%
244 - Natural Gas	923.72	3,500.00	-2,576.28	26.39%
245 - Telephone & Internet	2,809.05	4,250.00	-1,440.95	66.1%
261 - R & M - Veh & Equip	6,989.21	23,500.00	-16,510.79	29.74%
266 - Facility R & M	668.97	3,500.00	-2,831.03	19.11%
280 - Travel	710.65	1,750.00	-1,039.35	40.61%
295 - Trash pickup	193.03	325.00	-131.97	59.39%
300 - Fire Dept Supplies/ Misc.	1,853.94	3,000.00	-1,146.06	61.8%
301 - Cell Phones & Air Cards	0.00	1,260.00	-1,260.00	0.0%
320 - Parts & Supplies - Truck	82.06	3,000.00	-2,917.94	2.74%
325 - Turnout/Clothing	0.00	15,000.00	-15,000.00	0.0%
326 - Uniform/Clothing	857.00	4,000.00	-3,143.00	21.43%
331 - Fire Dept. Fuel	4,263.56	14,000.00	-9,736.44	30.45%
510 - Insurance	35,720.90	28,000.00	7,720.90	127.58%
562 - Tech - Annual Maint	8,074.93	13,850.00	-5,775.07	58.3%
563 - Tech - Hardware & Softwar	0.00	2,000.00	-2,000.00	0.0%
621 - Truck & Equip Testing	0.00	14,700.00	-14,700.00	0.0%
622 - Physicals & Testing	0.00	3,800.00	-3,800.00	0.0%
623 - Cleaning - Equip/TO	0.00	1,500.00	-1,500.00	0.0%
624 - On Truck Equip	16,840.37	28,000.00	-11,159.63	60.14%
636 - Ruth. Co. Emerg. Coord.	0.00	900.00	-900.00	0.0%
720 - Discretionary (Donation)	1,070.03	1,000.00	70.03	107.0%
Total 42200 · Fire Dept.	273,483.27	521,876.00	-248,392.73	52.4%

City of Eagleville
Profit & Loss Budget vs. Actual
July 2025 through February 2026

	<u>Jul '25 - Feb 26</u>	<u>Budget</u>	<u>\$ Over Budget</u>	<u>% of Budget</u>
44400 · Parks & Recreation				
111 - Salary -Park/Maint Super,	30,403.76	49,424.00	-19,020.24	61.52%
113 - Salaries - Maintenance	0.00	878.00	-878.00	0.0%
140 - Retirement	2,393.52	3,672.00	-1,278.48	65.18%
141 - Payroll Taxes	2,225.59	3,848.00	-1,622.41	57.84%
142 - Insurance	5,112.00	7,896.00	-2,784.00	64.74%
146 - Workman's Comp	1,005.89	1,710.00	-704.11	58.82%
147 - Unemployment Tax	0.00	100.00	-100.00	0.0%
241 - Electricity	2,720.59	4,100.00	-1,379.41	66.36%
242 - Water	141.97	475.00	-333.03	29.89%
245 - Phone	567.32	1,300.00	-732.68	43.64%
250 - Professional Services	10,000.00	13,000.00	-3,000.00	76.92%
260 - Maintenance	7,563.16	10,500.00	-2,936.84	72.03%
295 - Trash pickup	600.00	950.00	-350.00	63.16%
299 - Misc.	173.94	750.00	-576.06	23.19%
300 - Supplies	697.27	2,000.00	-1,302.73	34.86%
312 - Equipment	1,018.83	1,500.00	-481.17	67.92%
320 - Concession Stand	9.48	2,000.00	-1,990.52	0.47%
331 - Fuel	749.07	1,500.00	-750.93	49.94%
510 - Insurance	5,855.17	3,200.00	2,655.17	182.97%
562 - Tech - Annual Maint	175.94	335.00	-159.06	52.52%
583 - Fall Festival	14,465.21	12,000.00	2,465.21	120.54%
584 - Christmas Events	6,171.47	6,000.00	171.47	102.86%
585 - Summer Events	1,500.00	2,500.00	-1,000.00	60.0%
Total 44400 · Parks & Recreation	<u>93,550.18</u>	<u>129,638.00</u>	<u>-36,087.82</u>	<u>72.16%</u>

City of Eagleville
Profit & Loss Budget vs. Actual
 July 2025 through February 2026

	<u>Jul '25 - Feb 26</u>	<u>Budget</u>	<u>\$ Over Budget</u>	<u>% of Budget</u>
51000 · Other Financing Use				
51621 - Transfer to Street Aid	25,000.00	50,000.00	-25,000.00	50.0%
51630 - Transfer to Debt Servic	102,000.00	204,000.00	-102,000.00	50.0%
Total 51000 · Other Financing Use	<u>127,000.00</u>	<u>254,000.00</u>	<u>-127,000.00</u>	<u>50.0%</u>
Total Expense	<u>1,102,691.78</u>	<u>1,901,214.00</u>	<u>-798,522.22</u>	<u>58.0%</u>
Net Income	<u><u>416,539.61</u></u>	<u><u>656.00</u></u>	<u><u>415,883.61</u></u>	<u><u>63,496.89%</u></u>

7:25 AM
03/20/26
Accrual Basis

City of Eagleville-State Street Aid
Balance Sheet
As of February 28, 2026

	<u>Feb 28, 26</u>
ASSETS	
Current Assets	
Checking/Savings	
105 - Volunteer Bank SSA	16,730.42
LGIP - State Street Aid	325,378.77
100 - US Bank - Checking	3,000.00
Total Checking/Savings	<u>345,109.19</u>
Other Current Assets	
Due from General Fund	496.39
Total Other Current Assets	<u>496.39</u>
Total Current Assets	<u>345,605.58</u>
TOTAL ASSETS	<u><u>345,605.58</u></u>
LIABILITIES & EQUITY	
Equity	
350 - Fund Balance	329,976.23
Net Income	15,629.35
Total Equity	<u>345,605.58</u>
TOTAL LIABILITIES & EQUITY	<u><u>345,605.58</u></u>

7:25 AM
03/20/26
Accrual Basis

City of Eagleville-State Street Aid
Profit & Loss
February 2026

	<u>Feb 26</u>	<u>Jul '25 - Feb 26</u>
Income		
36100 - Interest Income	957.51	8,296.60
31730 - State of Tenn Gas Tax	2,075.66	19,000.92
Other Financing Source / Uses		
48500 - Transfer frm Gen. Fund	0.00	25,000.00
Total Other Financing Source / Uses	<u>0.00</u>	<u>25,000.00</u>
Total Income	<u>3,033.17</u>	<u>52,297.52</u>
Expense		
43100 - Street Aid Expenses		
900 - Capital Outlay	0.00	8,250.00
510 - Insurance	0.00	922.71
765 - Hwy & Street Permit Bond	0.00	100.00
260 - Repairs & Maintenance	891.29	6,285.51
247 - Street & Traffic Lights	1,507.66	10,568.55
248 - Contract Labor - Mowing	0.00	4,500.00
254 - Engineering	658.00	5,702.00
342 - Signs	0.00	339.40
Total 43100 - Street Aid Expenses	<u>3,056.95</u>	<u>36,668.17</u>
Total Expense	<u>3,056.95</u>	<u>36,668.17</u>
Net Income	<u><u>-23.78</u></u>	<u><u>15,629.35</u></u>

7:26 AM

03/20/26

Accrual Basis

**City of Eagleville-State Street Aid
Profit & Loss Budget vs. Actual
July 2025 through February 2026**

	Jul '25 - Feb 26	Budget	\$ Over Budget	% of Budget
Income				
36100 - Interest Income	8,296.60	4,000.00	4,296.60	207.4%
31730 - State of Tenn Gas Tax	19,000.92	29,000.00	-9,999.08	65.5%
Other Financing Source / Uses				
48500 - Transfer frm Gen. Fund	25,000.00	50,000.00	-25,000.00	50.0%
Total Other Financing Source / Uses	25,000.00	50,000.00	-25,000.00	50.0%
Total Income	52,297.52	83,000.00	-30,702.48	63.0%
Expense				
43100 - Street Aid Expenses				
900 - Capital Outlay	8,250.00	234,400.00	-226,150.00	3.5%
510 - Insurance	922.71	630.00	292.71	146.5%
765 - Hwy & Street Permit Bond	100.00			
260 - Repairs & Maintenance	6,285.51	7,000.00	-714.49	89.8%
247 - Street & Traffic Lights	10,568.55	18,670.00	-8,101.45	56.6%
248 - Contract Labor - Mowing	4,500.00	9,500.00	-5,000.00	47.4%
254 - Engineering	5,702.00	4,000.00	1,702.00	142.6%
342 - Signs	339.40	600.00	-260.60	56.6%
Total 43100 - Street Aid Expenses	36,668.17	274,800.00	-238,131.83	13.3%
Total Expense	36,668.17	274,800.00	-238,131.83	13.3%
Net Income	15,629.35	-191,800.00	207,429.35	-8.1%

Debt Service Fund
Balance Sheet
As of February 28, 2026

	<u>Feb 28, 26</u>
ASSETS	
Current Assets	
Checking/Savings	
Apex Bank - Checking	49,294.94
LGIP - Debt Service	223,943.18
Total Checking/Savings	<u>273,238.12</u>
Total Current Assets	<u>273,238.12</u>
TOTAL ASSETS	<u>273,238.12</u>
LIABILITIES & EQUITY	
Liabilities	
Current Liabilities	
Other Current Liabilities	
Due to General Fund	-20.00
Total Other Current Liabilities	<u>-20.00</u>
Total Current Liabilities	<u>-20.00</u>
Total Liabilities	-20.00
Equity	
Retained Earnings	447,388.42
Net Income	-174,130.30
Total Equity	<u>273,258.12</u>
TOTAL LIABILITIES & EQUITY	<u>273,238.12</u>

7:20 AM
 03/19/26
 Accrual Basis

Debt Service Fund
Profit & Loss
 February 2026

	Feb 26	Jul '25 - Feb 26
Ordinary Income/Expense		
Income		
36100 - Interest Income	632.73	6,266.70
Total Income	632.73	6,266.70
Expense		
219 - Emergency Comm Radios	0.00	16,371.00
555 - Bank Fees	0.00	0.00
679 - USDA \$722,200	0.00	28,910.00
680 - USDA \$3,777,800	0.00	141,177.00
681 - USDA \$2,009,600	-5,581.00	95,939.00
Total Expense	-5,581.00	282,397.00
Net Ordinary Income	6,213.73	-276,130.30
Other Income/Expense		
Other Income		
36961 - Transfer from General	0.00	102,000.00
Total Other Income	0.00	102,000.00
Net Other Income	0.00	102,000.00
Net Income	6,213.73	-174,130.30

7:21 AM
 03/19/26
 Accrual Basis

Debt Service Fund
Profit & Loss Budget vs. Actual
 July 2025 through February 2026

	<u>Jul '25 - Feb 26</u>	<u>Budget</u>	<u>\$ Over Budget</u>	<u>% of Budget</u>
Ordinary Income/Expense				
Income				
36100 - Interest Income	6,266.70	5,000.00	1,266.70	125.3%
Total Income	6,266.70	5,000.00	1,266.70	125.3%
Expense				
219 - Emergency Comm Radios	16,371.00	16,371.00	0.00	100.0%
555 - Bank Fees	0.00			
679 - USDA \$722,200	28,910.00			
680 - USDA \$3,777,800	141,177.00	170,087.00	-28,910.00	83.0%
681 - USDA \$2,009,600	95,939.00	95,939.00	0.00	100.0%
Total Expense	282,397.00	282,397.00	0.00	100.0%
Net Ordinary Income	-276,130.30	-277,397.00	1,266.70	99.5%
Other Income/Expense				
Other Income				
36961 - Transfer from General	102,000.00	204,000.00	-102,000.00	50.0%
Total Other Income	102,000.00	204,000.00	-102,000.00	50.0%
Net Other Income	102,000.00	204,000.00	-102,000.00	50.0%
Net Income	-174,130.30	-73,397.00	-100,733.30	237.2%

Capital Projects Fund
Balance Sheet
As of February 28, 2026

	Feb 28, 26
ASSETS	
Current Assets	
Checking/Savings	
Apex Bank - Money Market 6954	27,758.16
Apex Bank Checking - 6059	58,807.24
LGIP - Capital Projects	221,148.24
Total Checking/Savings	307,713.64
Other Current Assets	
Due from Sewer Fund	-525.00
Total Other Current Assets	-525.00
Total Current Assets	307,188.64
TOTAL ASSETS	307,188.64
LIABILITIES & EQUITY	
Liabilities	
Current Liabilities	
Other Current Liabilities	
Due to General Fund	49,711.91
Total Other Current Liabilities	49,711.91
Total Current Liabilities	49,711.91
Total Liabilities	49,711.91
Equity	
Retained Earnings	366,606.56
Net Income	-109,129.83
Total Equity	257,476.73
TOTAL LIABILITIES & EQUITY	307,188.64

7:17 AM
 03/19/26
 Accrual Basis

Capital Projects Fund
Profit & Loss
 February 2026

	Feb 26	Jul '25 - Feb 26
Ordinary Income/Expense		
Income		
33400 - State Grants	0.00	1,000.00
36100 - Interest Income	630.71	5,978.07
Total Income	630.71	6,978.07
Expense		
9000 - Capital Projects		
909 - Grant Match TDOT & TAP	0.00	7,000.00
914 - General Government	0.00	6,489.00
915 - Parks Improvements	0.00	7,990.00
916 - Police Equipment	0.00	51,372.90
918 - Demo of Old Bldg/Prkg Lot	0.00	43,256.00
Total 9000 - Capital Projects	0.00	116,107.90
Total Expense	0.00	116,107.90
Net Ordinary Income	630.71	-109,129.83
Net Income	630.71	-109,129.83

7:18 AM

03/19/26

Accrual Basis

Capital Projects Fund Profit & Loss Budget vs. Actual

July 2025 through February 2026

	Jul '25 - Feb 26	Budget	\$ Over Budget	% of Budget
Ordinary Income/Expense				
Income				
33400 - State Grants	1,000.00	1,200,000.00	-1,199,000.00	0.1%
36100 - Interest Income	5,978.07	5,000.00	978.07	119.6%
Total Income	6,978.07	1,205,000.00	-1,198,021.93	0.6%
Expense				
9000 - Capital Projects				
909 - Grant Match TDOT & TAP	7,000.00	1,376,500.00	-1,369,500.00	0.5%
914 - General Government	6,489.00	10,000.00	-3,511.00	64.9%
915 - Parks Improvements	7,990.00			
916 - Police Equipment	51,372.90	63,550.00	-12,177.10	80.8%
918 - Demo of Old Bldg/Prkg Lot	43,256.00	35,900.00	7,356.00	120.5%
919 - Radar Detection Poles	0.00	10,280.00	-10,280.00	0.0%
Total 9000 - Capital Projects	116,107.90	1,496,230.00	-1,380,122.10	7.8%
Total Expense	116,107.90	1,496,230.00	-1,380,122.10	7.8%
Net Ordinary Income	-109,129.83	-291,230.00	182,100.17	37.5%
Net Income	-109,129.83	-291,230.00	182,100.17	37.5%

7:37 AM

03/19/26

Accrual Basis

City of Eagleville Sewer Fund
Balance Sheet
As of February 28, 2026

	Feb 28, 26
ASSETS	
Current Assets	
Checking/Savings	
LGIP Investment Act	339,062.33
Wilson Bank - Money Market	272,413.73
101 · Wilson Bank & Trust	205,550.67
Total Checking/Savings	817,026.73
Accounts Receivable	
Allowance for Doubtful Accounts	-2,283.18
11000 · *Accounts Receivable	25,695.83
Total Accounts Receivable	23,412.65
Total Current Assets	840,439.38
Fixed Assets	
151 · Land	72,385.00
155 · Sewer Plant in Service	3,802,455.30
161 · Accumulated Depreciation	-820,725.37
170 · Construction in Progress	34,500.00
Total Fixed Assets	3,088,614.93
TOTAL ASSETS	3,929,054.31
LIABILITIES & EQUITY	
Liabilities	
Current Liabilities	
Other Current Liabilities	
Due to Capital Projects Fund	-525.00
141 · Due to General Fund	4,537.33
211 · Accounts Payable Accrual	4,976.59
Total Other Current Liabilities	8,988.92
Total Current Liabilities	8,988.92
Long Term Liabilities	
251 · Bonds Payable USDA 2013	1,348,220.00
252 · Bonds Payable USDA 2015	122,393.00
Total Long Term Liabilities	1,470,613.00
Total Liabilities	1,479,601.92
Equity	
301 · Retained Earnings	2,421,506.48
Net Income	27,945.91
Total Equity	2,449,452.39
TOTAL LIABILITIES & EQUITY	3,929,054.31

City of Eagleville Sewer Fund
Profit & Loss
February 2026

	Feb 26	Jul '25 - Feb 26
Ordinary Income/Expense		
Income		
37120 · Utility Income	19,814.61	159,584.53
37191 · Late Payment Penalty	310.59	1,937.93
37296 · Application Fees	0.00	500.00
Total Income	<u>20,125.20</u>	<u>162,022.46</u>
Expense		
52200 · Sewer Expenses		
259 · Profess Services (Grant)	4,537.33	10,587.11
241 · Electrical	1,365.06	6,514.84
254 · Engineering Services	0.00	-525.00
260 · Operation & Maintenance Charges	4,976.59	42,888.53
322 · Step Inspections	0.00	62.25
510 · Insurance	0.00	8,398.90
580 · Depreciation Expense	7,208.78	57,670.24
Total 52200 · Sewer Expenses	<u>18,087.76</u>	<u>125,596.87</u>
Total Expense	<u>18,087.76</u>	<u>125,596.87</u>
Net Ordinary Income	2,037.44	36,425.59
Other Income/Expense		
Other Income		
36100 · Interest Income	1,744.76	16,352.32
Total Other Income	1,744.76	16,352.32
Other Expense		
898 · Bond Interest	3,104.00	24,832.00
Total Other Expense	<u>3,104.00</u>	<u>24,832.00</u>
Net Other Income	<u>-1,359.24</u>	<u>-8,479.68</u>
Net Income	<u><u>678.20</u></u>	<u><u>27,945.91</u></u>

7:38 AM

03/19/26

Accrual Basis

**City of Eagleville Sewer Fund
Profit & Loss Budget vs. Actual
July 2025 through February 2026**

	Jul '25 - Feb 26	Budget	\$ Over Budget	% of Budget
Ordinary Income/Expense				
Income				
37120 · Utility Income	159,584.53	224,000.00	-64,415.47	71.2%
37191 · Late Payment Penalty	1,937.93	2,700.00	-762.07	71.8%
37296 · Application Fees	500.00	7,500.00	-7,000.00	6.7%
Total Income	162,022.46	234,200.00	-72,177.54	69.2%
Expense				
52200 · Sewer Expenses				
256 - Audit Fees	0.00	2,500.00	-2,500.00	0.0%
259 - Profess Services (Grant)	10,587.11	8,000.00	2,587.11	132.3%
241 - Electrical	6,514.84	13,000.00	-6,485.16	50.1%
254 - Engineering Services	-525.00	10,000.00	-10,525.00	-5.3%
258 - Permit Fees	0.00	1,000.00	-1,000.00	0.0%
260 · Operation & Maintenance Charges	42,888.53	60,000.00	-17,111.47	71.5%
261 - Grounds Maintenance	0.00	3,000.00	-3,000.00	0.0%
299 - Misc	0.00	1,000.00	-1,000.00	0.0%
322 - Step Inspections	62.25	2,500.00	-2,437.75	2.5%
510 - Insurance	8,398.90	5,500.00	2,898.90	152.7%
580 - Depreciation Expense	57,670.24	89,000.00	-31,329.76	64.8%
800 · Delinquency/Writeoffs	0.00	1,000.00	-1,000.00	0.0%
Total 52200 · Sewer Expenses	125,596.87	196,500.00	-70,903.13	63.9%
Total Expense	125,596.87	196,500.00	-70,903.13	63.9%
Net Ordinary Income	36,425.59	37,700.00	-1,274.41	96.6%
Other Income/Expense				
Other Income				
31021 - Grant Income	0.00	161,000.00	-161,000.00	0.0%
36100 · Interest Income	16,352.32	25,000.00	-8,647.68	65.4%
37195 · Capacity Fee	0.00	150,000.00	-150,000.00	0.0%
Total Other Income	16,352.32	336,000.00	-319,647.68	4.9%
Other Expense				
898 · Bond Interest	24,832.00	37,248.00	-12,416.00	66.7%
Total Other Expense	24,832.00	37,248.00	-12,416.00	66.7%
Net Other Income	-8,479.68	298,752.00	-307,231.68	-2.8%
Net Income	27,945.91	336,452.00	-308,506.09	8.3%

Developmental Impact Fund Balance Sheet

As of February 28, 2026

Feb 28, 26

ASSETS

Current Assets

Checking/Savings

Volunteer Bank - 6028 15,611.28

Total Checking/Savings 15,611.28

Total Current Assets 15,611.28

TOTAL ASSETS 15,611.28

LIABILITIES & EQUITY

Equity

Restricted for Park Facility 4,122.00

Restricted for Park Land 675.00

Restricted for Police Facilities 619.00

Restricted for Police Vehicles 840.00

Restricted for Fire Facilities 2,271.00

Restricted for Fire Apparatus 7,038.00

Restricted for Developmental Impact 46.28

Total Equity 15,611.28

TOTAL LIABILITIES & EQUITY 15,611.28

7:22 AM
03/19/26
Accrual Basis

Developmental Impact Fund
Profit & Loss
February 2026

	<u>Feb 26</u>	<u>Jul '25 - Feb 26</u>
Income		
34191 - Impact Fees - Res.	0.00	14,361.00
34192 - Impact Fees - Nonres	0.00	1,204.00
36100 - Interest Earnings	21.29	46.28
Total Income	<u>21.29</u>	<u>15,611.28</u>
Expense	<u>0.00</u>	<u>0.00</u>
Net Income	<u><u>21.29</u></u>	<u><u>15,611.28</u></u>

Item 8

Department Reports:

- City Recorder's Report
- Fire Department
- Parks Department
- Police Department



City Recorder's Report

TO: MAYOR AND COUNCIL

FROM: CITY RECORDER

Spring 2026 is shaping up to be one of the busiest for the City. The 2026-2027 budget preparations are in full swing; two annexations are underway, multiple grants are in progress and much more! The following are some of the highlights of the busyness:

Annexation Updates:

- Signage, notices and mailings for Parcel #120-46.00-000 (former Scales property) have been posted.
- The petition for annexation of the Moore property is on the agenda to be considered for referral to the Planning Commission.
- The public hearing, scheduled for this evening, reviews the annual progress report for Webb Road, annexed February 24, 2022.

Grants - At this time, we have multiple grants in progress:

- The Tennessee Highway and Safety Office (THSO) grant has been received for Police Chief Breniser and Corporal Joshua Silva-Bieber.
- The Recruitment and Retention grant was just received for Officers Isabella Willis and Justyn Rhodes.
- Reimbursement for the Fire Chief's new work station has been submitted. The City was awarded \$1900 toward the cost through the State and Local Cybersecurity Grant Program (SLCGP).
- Yesterday, we submitted an application to Tennessee Emergency Management Agency (TEMA) for reimbursement for funds expended during Winter Storm Fern in January.

General Updates:

- Recent updates to Laserfiche software have further improved how the system sorts scanned documents and places the documents in the appropriate folders. This improvement saves more time and increases the efficiency of records organization.
- Participation in retirement plans increased by 1/3 after the City Manager scheduled a representative from Empower to personally meet with each employee. Now, 75% of staff contribute to a retirement plan.

Christina Rivas
City Recorder

March 26, 2026



Fire Department Report – Eagleville Council Meeting 3/26/2026

Good evening, Mayor and Council,

The following are calls responded to by EFD from the council meeting on 2/26/2026 to today:

Total Calls - 28

16	EMS Calls
1	Brush fire
1	Structure Fire
1	Fire Alarm
3	MVA's
5	Public service
1	Smoke in Residence

As we near the end of our third month, we are currently at 87 runs for the year.

Lt. Maxwell has been attending EMT school with Bedford County EMS. He will be graduating April 9, 2026. We are working towards having each of our firefighters at the EMT level and higher. This will certainly make a difference medically for our citizens when our County supplied Ambulance is not in the city.

Lately, we have been working on our apparatus/equipment, getting them in tip top shape and looking good, as well as completing our annual firefighter fitness agility test.

We will be presenting our education trailer by summer. We are very excited about the chance to use this specific piece of equipment for fire safety education.

Again, we have 1 firefighter in basic fire school and 1 firefighter in First Responder Class. We appreciate their dedication and sacrifice.

I am very proud of our firefighters and their dedication to making our fire/rescue response exceptional for our citizens.

We thank each of you for the support of our Fire Department. If you have any questions, please reach out at any time

Thank you,

J. Armstrong



City of Eagleville

Will Vaughn, Park Director

February Park Report

- Rentals for February
 - 0-Pavillion Rental
 - 0-Field Rental
- Kevin is still working on winter projects at the park.
- No Park Board meeting in February
- Kevin has started working on fields to get them ready for spring as weather allows.
- Kevin continues clearing the brush along the ditch going into park.
- Budget turned in for Park.

P.O. Box 68, 1019 Ronnie Hill Blvd., Eagleville, TN 37060

C: (615) 589-6896

mudcats1980@gmail.com www.EaglevilleTN.gov

This institution is an equal opportunity provider and employer



City of Eagleville

David Breniser, Chief of Police

Eagleville Police Department Report to City Council

3/26/26

1) Attached is a statistics report which will now be done quarterly. January 1st, thru March 24th.

Eagleville Statistics, First Quarter

Date Range: January 1st – March 24th, 2026

Calls to Service

Abandon Vehicle	1	Escort/Funeral	6
Accident Injury	4	Lockout	0
Accident No Injury	7	Motorist Assist	4
Agency Assist	1	Property Exchange	3
Alarm; Burglar	12	Reckless Vehicle	0
Ambulance Assist	2	Scam Call	0
Animal At Large	1	Sexual Assault: Abuse	0
Arrest	0	Suicide Threats	1
Arrest due to D.U.I.	0	Suspicious Incident/Person/Vehicle	15
Attempt to Locate	3	Follow Up	5
Bolo	3	Theft	1
Corpse/ Overdose	1	Traffic Hazzard	8
Damage to Property	1	Trespassing	0
Disputes	1	Welfare Check	8
Domestic Dispute	1	Verbal Household	1
Fire Call	5	911 Hang Up	3
Forgery/Fraud	3	Stolen Property	1
Injured Animal	1	Violation of Bond	5

Traffic Citations

Speeding	53	Seatbelt Viol.	0
Speeding Warnings	15	No Passing Zone	3
Expired Registration	3	Improper Passing	2
No Proof of Registration	3	No DL in Possession	2
Viol. Proof of Insurance	2	County Violations	5
Other Violations	2	Other Warning	5

- 2) Officer Justyn Rhodes has successfully completed the Tennessee Highway Safety Office training course on Standardized Field Sobriety Testing.
- 3) Officer Isabella Willis has informed EPD of having received a Law Enforcement Scholarship based on her impressive academic achievement while attending Middle Tennessee State University and working full time as a Law Enforcement Officer. EPD is very proud of Officer Willis and wish her continued success in the future.
- 4) The EPD has just completed a full inventory of all department equipment and assets.

X 
 Chief Dave Breniser

P.O. Box 68, 259 North Main St., Eagleville, TN 37060

T: (615) 640-9612 C: (615) 203-2781

dbreniser@eaglevilletn.gov www.EaglevilleTN.gov

This institution is an equal opportunity provider and employer



City of Eagleville

David Breniser, Chief of Police

To whom it may concern, I have served the City of Eagleville as the Chief of Police for the past 13 years. In that time, I have worked many accidents at the intersection of South Main Street and Hwy 99. As the city grows more and more every day, the traffic volume increases. So, today, I ask the Tennessee Department of Transportation to review its roads and all traffic safety options that can be implemented as soon as possible. The following photos of existing signs along with cost estimates of solar panel flashing lights to replace them is requested. In addition, a yellow directional sign be installed on the west side of South Main Street.

Sincerely

Chief Dave Breniser

Eagleville Police Dept.

P.O. Box 68, 259 North Main St., Eagleville, TN 37060

T: (615) 640-9612 C: (615) 203-2781

dbreniser@eaglevilletn.gov www.EaglevilleTN.gov

This institution is an equal opportunity provider and employer



City of Eagleville

David Breniser, Chief of Police

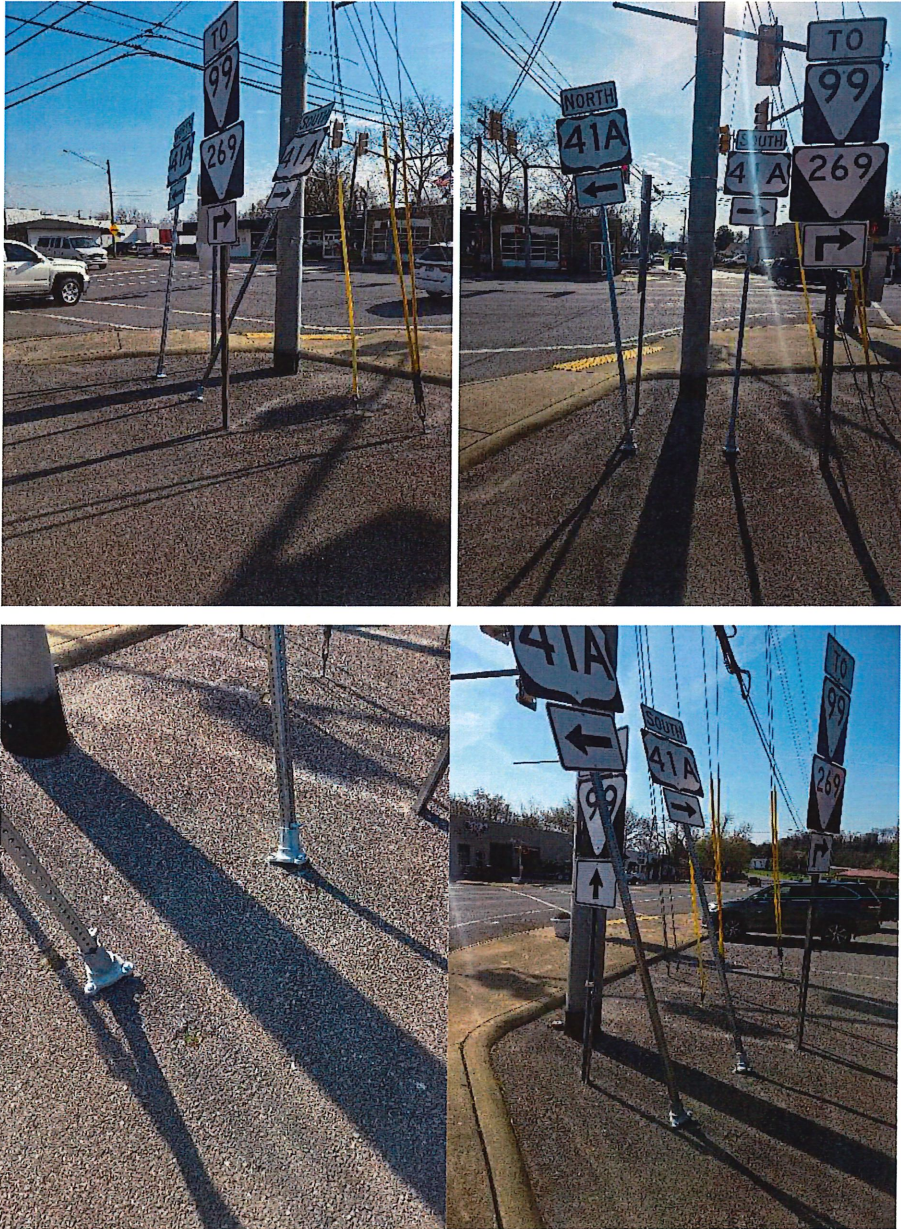

These signs were recently repaired by T-dot. As of today, they have failed to stay in place. These are located at the intersection of Main Street and Allisona Road in the parking lot of City Hall.

P.O. Box 68, 259 North Main St., Eagleville, TN 37060

T: (615) 640-9612 C: (615) 203-2781

dbreniser@eaglevilletn.gov www.EaglevilleTN.gov

This institution is an equal opportunity provider and employer



City of Eagleville

David Breniser, Chief of Police



Industrial & Scientific > Occupational Health & Safety Products > Safety Signs & Signals > Warning Lights



Click to see full view

28" Solar Yield Sign - LED Flashing Crossing Sign, Aluminum Yield Road Warning Signs Traffic with Mounting Accessories(A,71cm/28in)

Brand: Fenghal

\$239⁰⁰

Size: 71cm/28in

Color: A

- Rustproof metal frame, the edges are fully sealed to be waterproof and dustproof, so it can be used for a long time in any weather.
- Engineer grade reflective Film +The High Intensity White LED blinking lights, at least 1/2 miles visual distance.Up to 7 Years of outdoor durability.
- YIELD Pedestrian Crossing for Solar Powered Signs.It can continue working for 5 days even on rainy days (insufficient sun light) when fully charged. Built-in light sensor, automatically turns on when the light is low.
- Pre-installed U-shaped hoop mount,Applicable column diameter: 76/89mm. Easy to mount to square or round galvanized posts, wooden posts and chain link fences, etc.
- Please note that the product only includes the yield crosswalk sign + solar panel + U-shaped hoop mount. You need to prepare the vertical column of the right size by yourself. Please understand.

\$239⁰⁰

FREE delivery April 6 - 15.

[Details](#)

Delivering to Eagleville 37060 - Update location

In Stock

Quantity: 1

Add to cart

Buy Now

Shipper / Seller Fenghal.

Returns 30-day refund/replacement

Payment Secure transaction

Add to List



Two signs to be purchased from Amazon for \$239.00 each (Total \$478.00). They can be installed on the existing poles where the current yield signs already exist. Installation by the City of Eagleville.

P.O. Box 68, 259 North Main St., Eagleville, TN 37060

T: (615) 640-9612 C: (615) 203-2781

dbreniser@eaglevilletn.gov www.EaglevilleTN.gov

This institution is an equal opportunity provider and employer



City of Eagleville

David Breniser, Chief of Police



Sponsored

Tools & Home Improvement • Lighting & Ceiling Fans • Commercial Lighting • Street & Area Lighting

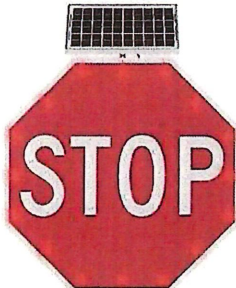

Click to see full view

24" Solar Stop Sign Solar Powered LED Blinking Reflective Street Traffic Warning Sign Octagon Rust-proof Metal Frame

Brand: Allxcent
5.0 (1)

Price: See price in cart

Brand Allxcent
Size 24" Red
Color Red
Material Aluminum
Mounting Floor Standing, Pole Mount
Type
Item Weight 12.1 Pounds

See more

About this item

- Engineering-grade reflective film
 - Easy Install
- See more product details

Report an issue with this product or seller

FREE delivery Friday, April 10.

Details

Delivering to Eagleville 37060 - Update location

Usually ships within 6 to 7 days

Quantity: 1

Add to cart

Buy Now

Shipper / Seller Allxcent

Returns 30-day refund/replacement

Payment Secure transaction

Add to List



This sign could be purchased from Amazon for \$299.99. It can be mounted on the existing pole in the middle of the intersection; however, this sign frequently gets hit and knocked over by normal traffic operations. Damage to this solar panel sign could be repetitive. Installation by the City of Eagleville. Total cost \$299.99.

P.O. Box 68, 259 North Main St., Eagleville, TN 37060

T: (615) 640-9612 C: (615) 203-2781

dbreniser@eaglevilletn.gov www.EaglevilleTN.gov

This institution is an equal opportunity provider and employer



City of Eagleville

David Breniser, Chief of Police

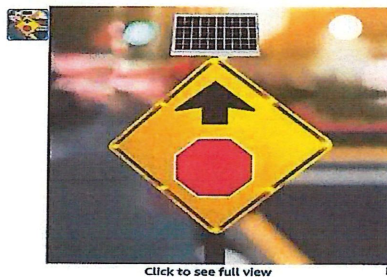
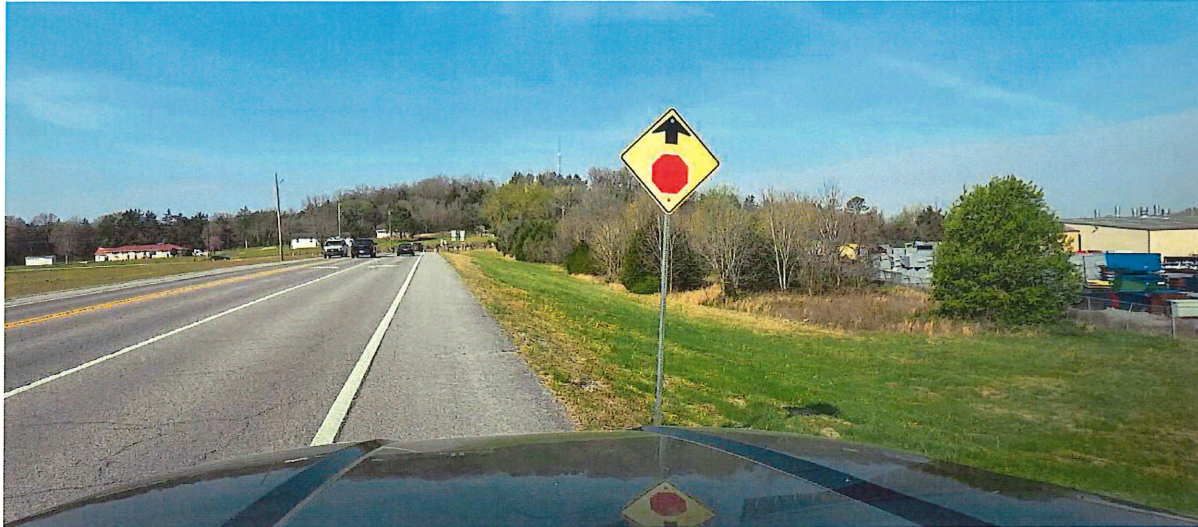

Click to see full view

24" Stop Ahead Graphic Sign, Solar Power Flashing LED Traffic Road Warning Signs, Stop Ahead Sign with Engineer Grade Reflective Film

Brand: Lmekoe

~~\$243.99~~

Save 5% on 2 select item(s) Shop Items >

Save 7% on 4 select item(s) Shop Items >

Brand Lmekoe
Color yellow
Product 24"L x 24"W
Dimensions
Manufacturer Lmekoe

About this item

- ★ **[24" Stop Ahead Sign]** The stop ahead sign is ideal for raising safety awareness and alerting pedestrians and vehicles. It features an innovative LED lighting system with a solar panel and U-shaped bracket included
- ★ **[High-quality Reflective Film]** Strong reflective effect at night, long lifespan, technical-grade reflective material (visible distance > 800 meters), very practical
- ★ **[Outdoor Use]** UV-resistant technical-grade reflective film, can be used continuously even in harsh conditions, for 7 days on cloudy days. Durable and robust
- ★ **[LED Lighting]** This high-visibility flashing sign warns pedestrians and vehicles. Intelligent light control, energy saving after switching on, no flashing during the day and automatic flashing at night, for longer battery life and longer endurance
- ★ **[IP65 Dustproof and Waterproof]** Robust and rustproof aluminum sheet frame, durable and designed to withstand harsh weather, especially strong winds. The IP65 waterproof rating prevents rainwater from seeping in, ensuring long-lasting use

> See more product details

~~\$243.99~~

FREE delivery April 9 - 23.
[Details](#)

Delivering to Eagleville 37060 -
Update location

In Stock

Quantity: 1

Add to cart

Buy Now

Shipper / Seller JDKMNE

Returns 30-day
refund/replacement

Payment Secure transaction

Add to List



Sponsored

This sign could be purchased from Amazon for \$243.99. It can be mounted on the existing pole. Installation by the City of Eagleville. Total \$243.99

P.O. Box 68, 259 North Main St., Eagleville, TN 37060

T: (615) 640-9612 C: (615) 203-2781

dbreniser@eaglevilletn.gov www.EaglevilleTN.gov

This institution is an equal opportunity provider and employer



City of Eagleville

David Breniser, Chief of Police



The Eagleville Police Department requests that TDOT consider all safety options at the T intersection of Highway 99 and South Main Street including repainting the fading arrows for turning traffic. Possible instillation of rumble strips and a directional arrow sign installed on the West side of South Main Street.

P.O. Box 68, 259 North Main St., Eagleville, TN 37060

T: (615) 640-9612 C: (615) 203-2781

dbreniser@eaglevilletn.gov www.EaglevilleTN.gov

This institution is an equal opportunity provider and employer

Item 9 City Manager's Report



City Manager's Report February 26, 2026

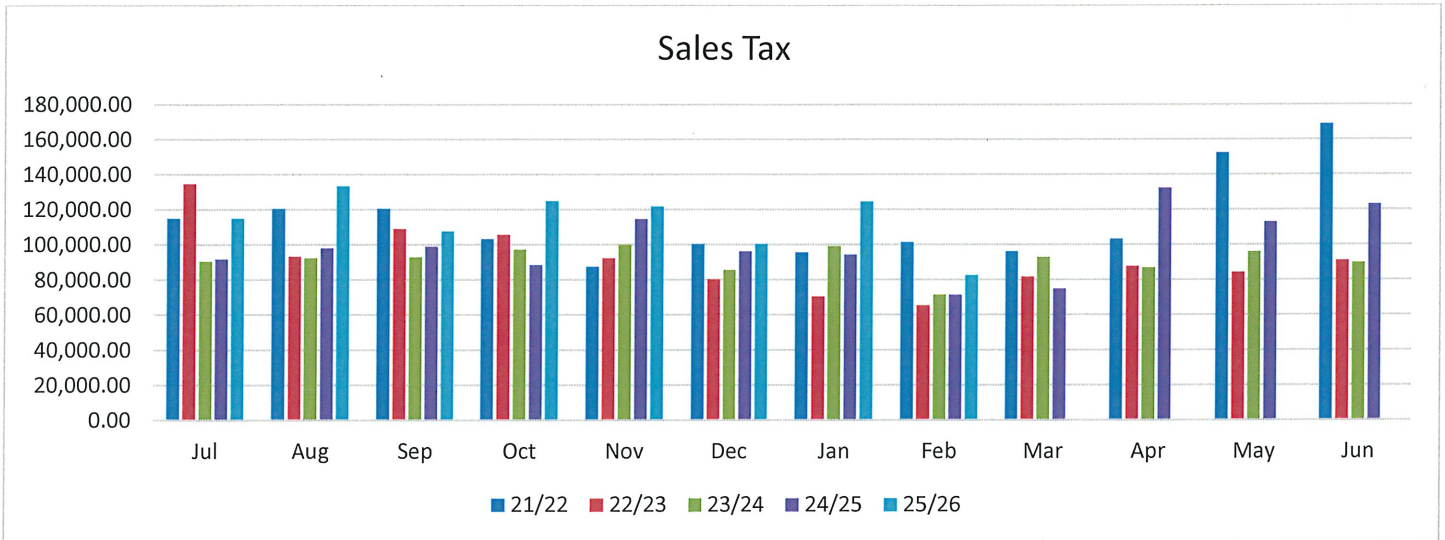

Jul	Aug	Sep	Oct	Nov	Dec	Jan	Feb	Mar	Apr	May	Jun
115,005.53	120,682.18	120,680.70	103,347.59	87,547.68	100,427.24	95,647.29	101,466.12	96,133.53	103,284.36	152,570.06	168,927.99
134,804.91	93,243.94	109,033.87	105,812.38	92,384.89	80,320.51	70,608.37	65,398.21	81,635.37	87,855.48	84,322.52	91,123.50
90,585.69	92,424.62	92,861.15	97,253.25	99,989.41	85,631.94	99,161.63	71,540.19	92,950.55	86,854.64	95,983.98	89,740.17
91,864.33	98,125.69	99,016.01	88,554.91	114,654.98	96,249.40	\$94,418.23	71,447.26	74,980.77	132,373.78	113,040.98	123,201.49
115,042.97	133,464.02	107,739.78	\$125,039.75	121,796.42	100,471.87	124,656.48	82,619.25				

FY 2025-2026 Building Permits & Codes

	Feb	Mar	Apr	May	June	July	Aug	Sept	Oct	Nov	Dec	Jan	Feb
New Res.	0	0	2	0	0	0	1	0	1	1	0	0	0
Res Add.	0	1	0	0	0	0	0	0	0	0	1	0	1
Res. Plumb/Mech	0	0	0	0	0	0	0	2	2	2	2	0	1
Res. Other/Accessory	1	1	0	0	0	0	0	0	0	0	0	0	0
New Com.	0	0	0	0	0	0	0	0	0	0	0	0	0
Com. Add.	0	1	0	0	0	0	0	0	0	0	0	1	1
Com. Plumb/Mech/Gas	0	0	4	1	2	0	0	1	1	1	0	0	0
Com. Other	1	1	0	1	0	1	0	0	0	0	0	0	0
Signage	0	0	0	0	2	0	0	0	0	0	1	0	0
Pool	0	0	0	0	0	1	0	0	1	0	0	0	0
Sewer Capac.	0	0	0	0	0	0	0	0	0	0	0	0	0
Violation Notice	0	0	0	0	0	0	0	0	0	0	1	0	0
Site Plan Reviews	0	0	0	0	0	0	0	0	0	0	0	0	0
Plat Application	0	0	0	0	0	0	0	0	0	0	0	0	0
Rezoning App.	0	0	0	0	0	0	0	0	0	0	0	0	0
BZA & Other Misc.	0	0	0	0	0	0	0	0	0	0	0	0	0

News, and Notes:

Important Information:

City Manager: (1) As City Manager, I will always make myself available to any council member to discuss current or on-going concerns with the City. I am also always open to feedback and suggestions of ways we can improve. (2) The Long-Range Committee continues to meet. We are reviewing the Long-Range Plan, now including the Urban Growth Boundary (UGB) and changes to our Zoning Ordinance. We are working on the ARP grant for sewer extension, if possible. (3) The City Manager's meeting with the Planners and Engineers in Rutherford County for March was canceled. Still waiting on the group to tackle Urban Growth Boundaries. (4) Per Council's direction, Will Owen is preparing various options for the parking lot at the former Police/Fire site. City Manager and Mike Walker are reviewing a sketch that has been submitted. Will be working with Will Owen to review costs. (5) At your March meeting, a potential Eagle Scout will present a project that he would like to do at the Ronnie Hill Memorial Park.

Pending Projects: (1) With the Traffic Speed Study completed, City Manager is writing a comprehensive speed limit ordinance. (2) Review, Edits and Updates to the Personnel Policy. (3) City Manger writing a resolution showing all existing streets that have been accepted, with future resolutions to be adopted as new streets are added.

Budget News: (1) City Manager and City Recorder have turned in all numbers to Mike Walker, who has prepared a budget to be presented at your work session in April. April 23 will be the first reading and May 28 will be second reading and public hearing. Please be ready to present any capital improvements you may want to see in the upcoming budget. Mike Walker will also present an amendment to this year's budget to allow for some capital projects to be done.

Finance Report: Sales tax decreased in February but was still higher than last February's amount. Overall, the year is higher than last year and sales tax has been strong.

Planning/Codes: 1. You now have two pending annexations. The 97 acre tract for Salem Creek property is up for a vote. You will be starting the process to possibly annex the approximately 266 acre tract at the north end of the county line. 2. The AT&T Building has been cleaned up from the dumping that was done. 3. City Manager/Planner will propose more updates to the Zoning Ordinance. The current ordinance has been codified with all amendments thus far.

Streets and Drainage: (1) Paving and modification to the paving is complete. Will Owen needs to review and then payment will be made. (2) I will be approving a new street light in New Town to cover a dark area, now that the paving is complete. (3) As part of the budget review, street paving/improvements in the upcoming years should be reviewed.

Sewer: (1) Will Owen is preparing a Sewer Operator RFQ/P for us to engage for Stephenson Farms. Will Owen will perform the inspections of the STEP plant as it is being constructed. (2) I have been in touch with a property owner for potential discussions of land for purchase of a STEP system for the south end of our city. I am waiting to hear back from them.

City Recorder: See separate report from Christina Rivas.

Engineering Report: No report. We are hoping to have Will Owen attend your next work session to update us all on projects.

Parks & Recreation/Maintenance: See separate report from Will Vaughn.

Events (from Katy Sanderson): We are contemplating several projects and appreciate any input you would like to share with us.

- A small time-capsule. Included in the time capsule we'd like:
 - a letter from the Mayor and Council
 - photos of Eagleville now
 - information on current events
- Music on the porch of City Hall
- Assorted food trucks
- A beautiful and festive photo display set up for people to take their own photos
- A children's booth with free items including an Eagleville coloring book
- A limited number of native seedlings to give away from the Arbor Society
- A brief history of Eagleville in print and available digitally through a QR code
- We have our next meeting on April 7th to discuss progress on all the projects, cost and finalize the date.

Library: Back reports have been submitted. City Manager has requested that we receive a monthly report.

Upcoming Meetings/Events:

April 3, 2026	City Hall closed for Good Friday
April 6, 2026	BZA, Design Review, Public Hearing & Planning Commission, 6:00/6:30 p.m.
April 14, 2026	Municipal Court, 11:00 a.m.
April 9, 2026	City Council Work Session, 7:00 p.m.
April 23, 2026	Regular City Council Meeting & Public Hearing, 7:00 p.m.

Item 10a Ordinance 2026-003 Street Acceptance Policy

ORDINANCE NO. 2026-003

AN ORDINANCE AMENDING TITLE 16, SECTION 16-112 OF THE EAGLEVILLE MUNICIPAL CODE: STREET ACCEPTANCE POLICY

Whereas, Section 16-112 of the Eagleville Municipal Code describes a policy for Street Acceptance; and

Whereas, Section 16-112 should be expanded for clarity;

Whereas, the Eagleville City Council desires to amend Section 16-112;

NOW THEREFORE, BE IT ORDAINED by the City of Eagleville, Tennessee City Council that Section 16-112 of the Eagleville Municipal Code is hereby struck in its entirety and amended to read:

16-112. Street acceptance policy. The City of Eagleville shall not, nor shall any public authority accept, open, improve, grade or pave any street unless such street has been accepted as or shall have otherwise received the legal status of a public street.

No street within the City of Eagleville shall be accepted or otherwise receive the legal status of a public street without adhering the following requirements:

(1) It has been constructed by the city or under contract with the city and construction is substantially complete; or

(2) The street has been constructed in compliance with the city's subdivision regulations; and

(b) No street within the city shall be accepted or opened as or shall have otherwise received the legal status of a public street without prior inspection and approval by the city engineer and city planner.

(c) The owner of any subdivision or his agent shall pay to the city an inspection fee for each linear foot on all streets in any subdivision, in compliance with the current subdivision regulations of the city. The fee shall be paid prior to the opening, improving, grading or paving of any streets. The amount of such inspection fee shall be established by the city manager, and adopted by the City Council, from time to time as deemed appropriate to fully recover the cost of the services.

(3) A resolution accepting the street has been passed by the Eagleville City Council.

Be it Ordained by the City of Eagleville, Tennessee that this Ordinance shall become effective on _____, in accordance with the Charter of the City of Eagleville, Tennessee, and the public welfare demanding it.

Approved and adopted by the City of Eagleville, Tennessee, Mayor and the Eagleville Councilmembers.

Date

Chad Leeman, Mayor Tennessee

ATTEST:

Christina Rivas, City Recorder

First Reading: _____

Second Reading: _____

APPROVED AS TO FORM:

Date

Stephen Aymett, City Attorney

Item 10b Progress Report for Parcel Annexed February 24, 2022

March 2026

A. Plan of Service for Map/ Parcel 141 00100 (742 W. Webb Road)

- 1) Police patrol and respond to any calls on these parcels.
- 2) Fire Service responds to any calls on these parcels.
- 3) Water is provided by CUD.
- 4) Wastewater – A STEP System is to be constructed by the developer or in collaboration with another developer. Once completed, the City has agreed to take over the Operation and Maintenance of the STEP System. The STEP System has not been constructed by the developer at this time.
- 5) Garbage Collection – the City does not provide garbage collection services to any citizen.
- 6) Streets- City has patched potholes as needed, and will continue to maintain before and after developer makes improvements.
- 7) Schools – This is part of the Rutherford County School system and students will be sent to schools according to County Zoning.
- 8) Inspections and Code enforcement – as structures are constructed, the City will provide inspection and code enforcement.
- 9) Zoning – Zoning assigned as R-2 PRD.
- 10) Street Lighting – street lighting will be provided by the developer.
- 11) Recreation – residents will be included in any recreational activities or areas, including Ronnie Hill Park.

Staff recommends that progress reports for this Annexation be carried over until such time as the STEP system is turned over to the City for Operation and Maintenance.

Item 11a Eagle Scout Project for Ronnie Hill Park by Brendan Tomlinson

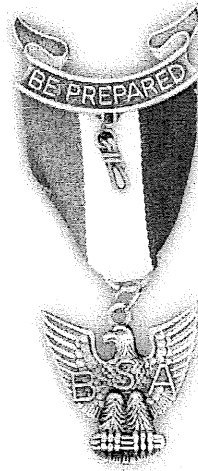

Eagle Scout Service Project Proposal



BOY SCOUTS OF AMERICA®

Eagle Scout candidate's full legal name Brenden Porter Tomlinson

Please give a name to your project Eagleville Fit for All

WiseFit Outdoor Fitness Equipment

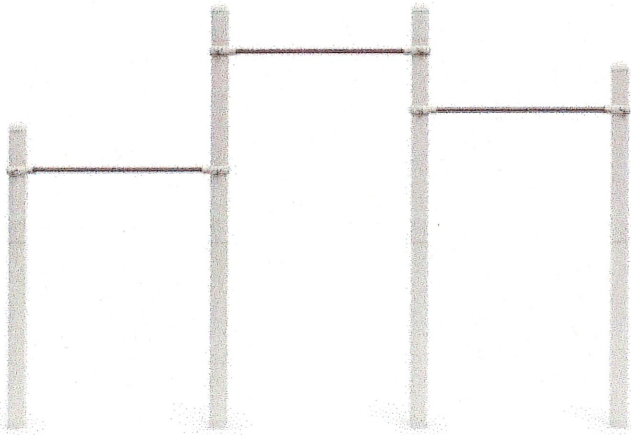

Wise TRI Level Bars

SKU: QSFS-CL002IN

Category: [WiseFIT](#)

Age: 14+

Fall Height: 75"

Use Zone: 300SF

Equipment Size: 10'6" x 6" x 71"

Timbers: N/A

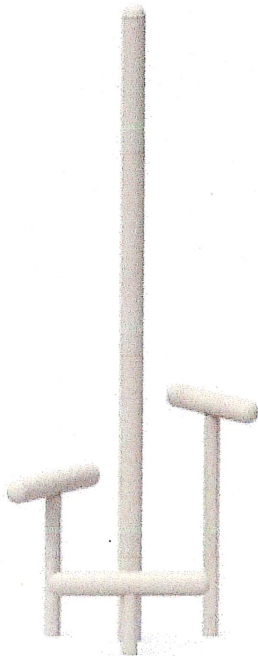

Wise Step Up

SKU: 79-23005

Category: [WiseFIT](#)

Age: 14+

Fall Height: N/A

Use Zone: 240SF

Equipment Size: 3'1" x 2'9" x 7'9"

Timbers: N/A

WiseFit Outdoor Fitness Equipment

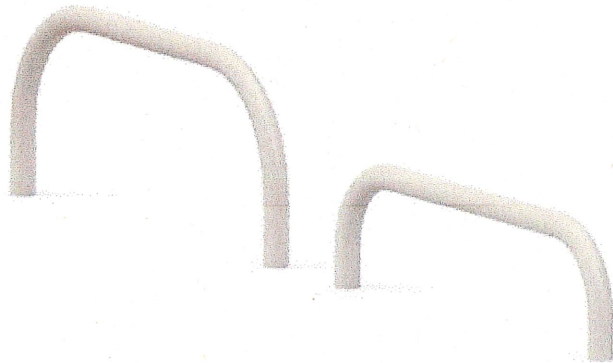

Q

Wise Push Up Bars

SKU: 79-23003 Category: [WiseFIT](#)

Age: 14+

Fall Height: N/A

Use Zone: 221SF

Equipment Size: 2" x 4'8" x 10"

Timbers: N/A

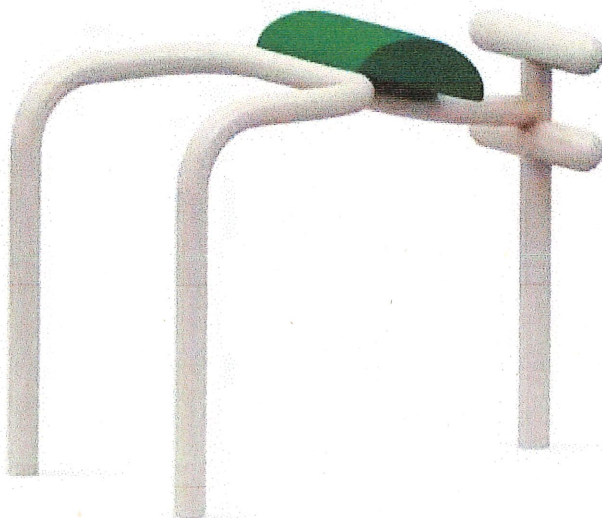

Q

Wise Bench

SKU: 79-23001 Category: [WiseFIT](#)

Age: 14+

Fall Height: N/A

Use Zone: 240SF

Equipment Size: 2'4" x 3'10" x 3'2"

Timbers: N/A

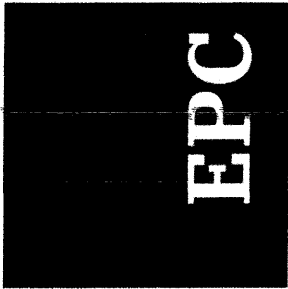

ELEVATE PLAY COLLECTIVE

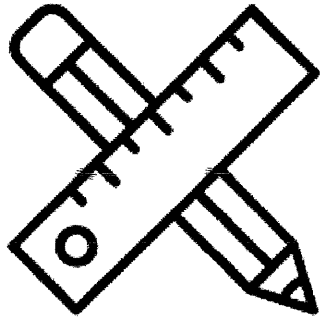

PLANNING AND DESIGN

We specialize in unique and thoughtful play space design. Whether it's a renovation of an existing play area or a completely new ground-up design, lean on our expertise to ensure you don't end up with a forgettable play space.

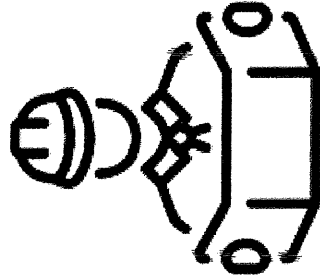

INSTALLATION SERVICES

We offer a range of installation services from new equipment and surfacing to repairs of existing spaces. Whether it's guidance in your layout design or help with detailed construction processes, reach out to see how we can assist.

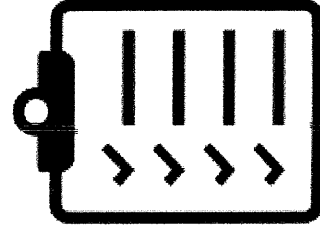

INSPECTIONS AND AUDITS

Unsure if your playground is compliant with current safety standards? We offer regular inspections as well as more comprehensive safety audits to ensure compliance. Let us help with a detailed plan to address your needs.



MAINTENANCE AND REPAIRS

Do you have an existing playground that needs attention? From broken equipment to safety surfacing maintenance, we can help ensure your play space is compliant to current ASTM and CPSC standards.

Layout 1

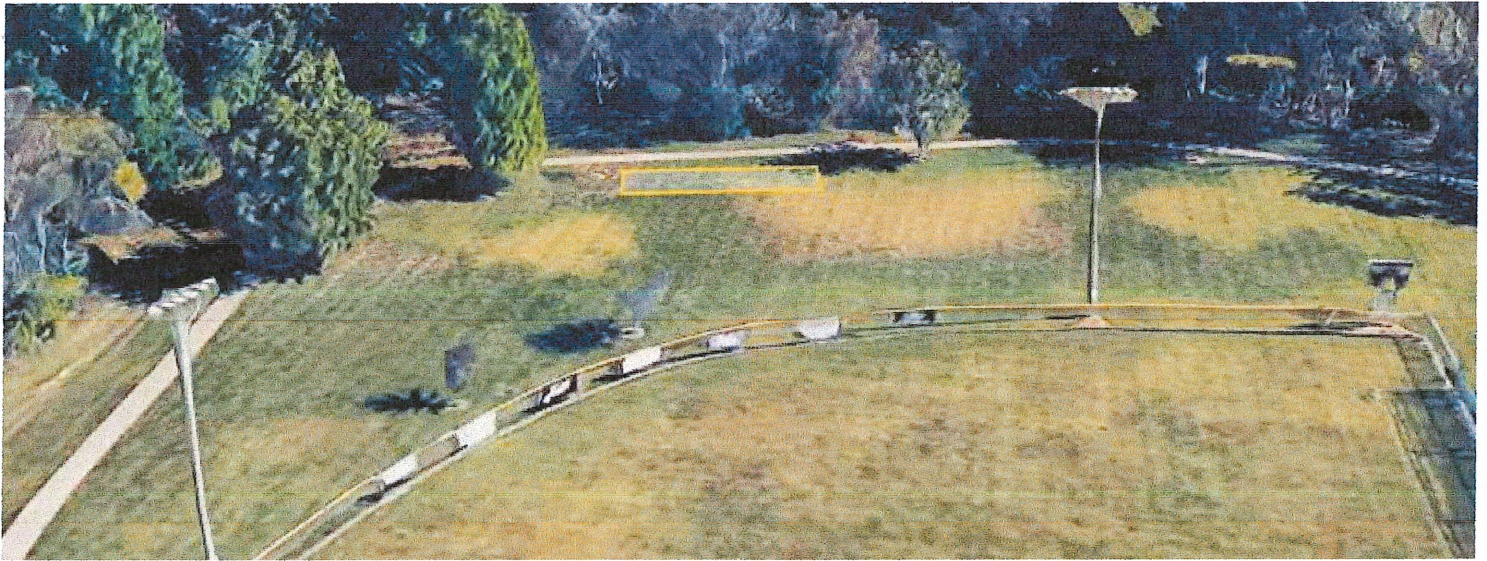
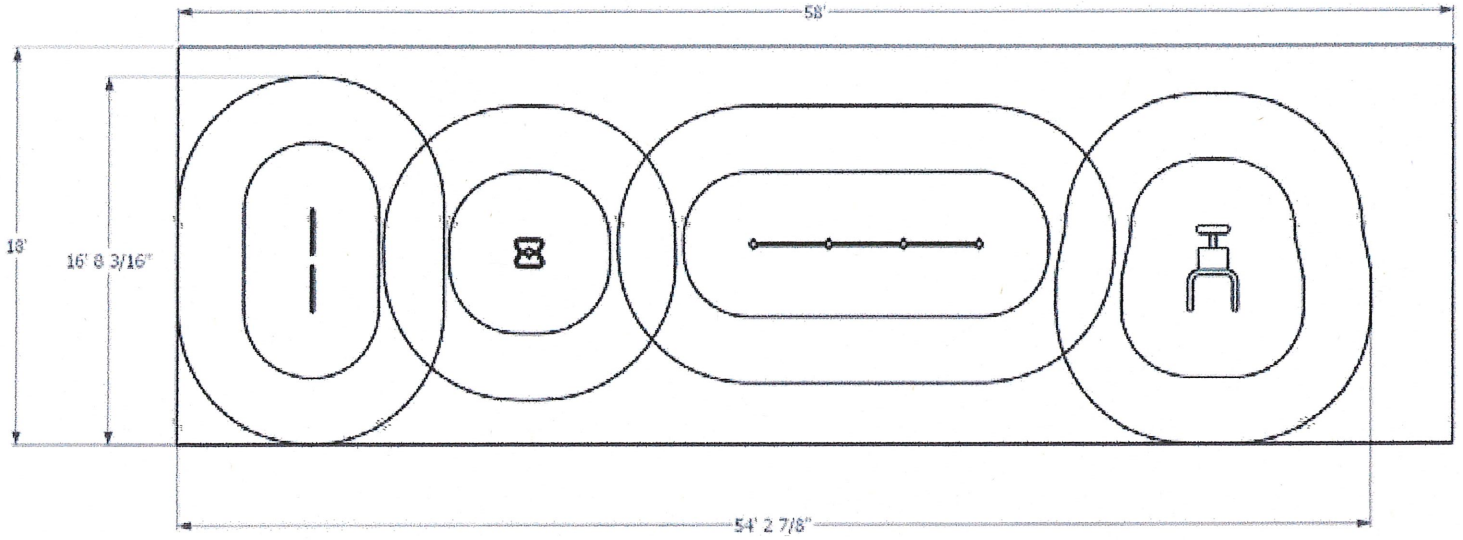

Layout 2

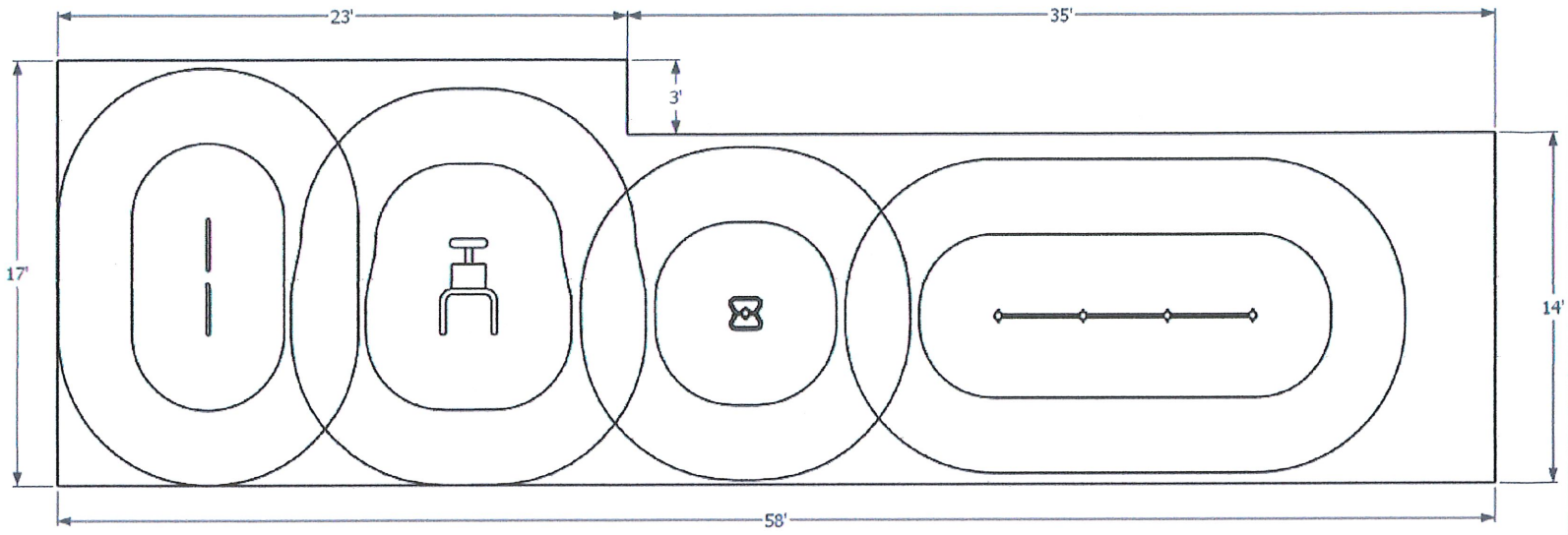

Layout 3

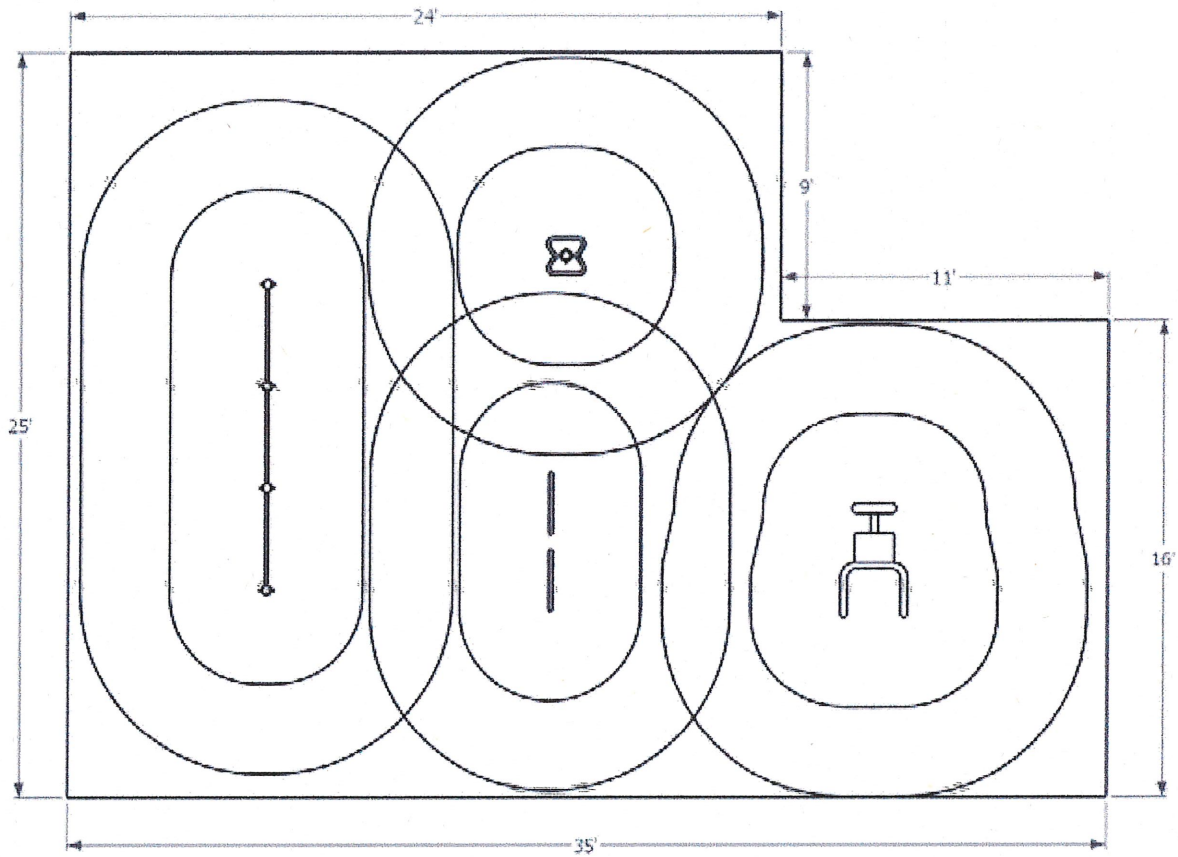

Contact Information

Eagle Scout candidates should know who is involved, but contact information may be more important to unit leaders and others in case they want to talk to each other. While it is recognized that not all the information will be needed for every project, Scouts are expected to provide as much as reasonably possible. Approval representatives must understand, however, that doing so is not part of the service project requirement.

Eagle Scout Candidate

Name: Brenden Porter Tomlinson		Birth date: July 11, 2011	
Email Address: bportert@icloud.com		BSA PID number: 134334506	
Address: 3441 Highway 41A North	City: Eagleville	State: TN	Zip: 37060
Preferred telephone(s): 615-712-0785		Life Board of Review date: 12/02/2024	

Current Unit Information

Check One: <input checked="" type="radio"/> Troop <input type="radio"/> Crew <input type="radio"/> Ship	Unit Number: 441
Name of District: Trail of Tears	Name of Council: Middle Tennessee Council

Unit Leader Check One: Scoutmaster Crew Advisor Skipper

Name: Adam Holt	Preferred telephone(s):		
Address:	City:	State:	Zip:
Email Address:			

Unit Committee Chair

Name: Tim Burns	Preferred telephone(s):		
Address:	City:	State:	Zip:
Email Address: TimBurns.troop441@troopmaster.email			

Unit Advancement Coordinator

(If your unit has one)

Name: Daniel Webber	Preferred telephone(s):		
Address:	City:	State:	Zip:
Email Address:			

Project Beneficiary

(Name of religious institution, school or community)

Name: City of Eagleville	Preferred telephone(s): 615-274-2922		
Address: 108 South Main Street	City: Eagleville	State: TN	Zip: 37060
Email Address: hriggins@eaglevilletn.org			

Project Beneficiary Representative

(Name of contact person for the project beneficiary)

Name: Will Vaughn	Preferred telephone(s): 615-289-6896		
Address: 1019 Ronnie Hill Avenue	City: Eagleville	State: TN	Zip: 37060
Email Address: mudcats1980@gmail.com			

Your Council Service Center

Contact Name: David Phillips	Preferred telephone(s): 615-383-9724		
Address: 3414 Hillsboro Pike	City: Nashville	State: TN	Zip: 37215
Email Address: david.phillips@scouting.org			

Council or District Project Approval Representative

(Your unit leader, unit advancement coordinator, or council or district advancement chair may help you learn who this will be.)

Name: Mindi Bell	Preferred telephone(s): 615-653-3687		
Address:	City:	State: TN	Zip:
Email Address: mbellbsa@gmail.com			

Project Coach

(Your council or district project approval representative may help you learn who this will be.)

Name:	Preferred telephone(s):		
Address:	City:	State:	Zip:
Email Address:			

Project Description and Benefit

Briefly describe your project

There is a city park in Eagleville that includes a walking track. For my project, I would like to plan, organize, and install outdoor fitness equipment to give people who walk around the track more options for exercise.

Include images on an additional document.

Tell how your project will be helpful to the beneficiary. Why is it needed?

This project will be helpful to the community because the fitness equipment that I am wanting to add to the park will offer a variety of exercise options for specific areas of the body outside of just walking or running around the track.

When I approached the city to ask about doing this project, they said they have wanted to add fitness equipment for a long time, but have not gotten around to it.

When do you plan to begin carrying out your project?

Middle of April

When do you think your project will be completed?

End of May

Giving Leadership

10

Approximately how many people will be needed to help on your project?

Where will you recruit them (unit members, friends, neighbors, family, others)?

I will recruit individuals from: Scout Troop, School Friends, Family Members, Community Members, and Industry Professionals.

What do you think will be most difficult about leading them?

Figuring out who will be the best at what.

Materials

Materials are things that become part of the finished project, such as lumber, nails and paint.

What types of materials, if any, will you need? You do not need a detailed list or exact quantities, but you must show you have a reasonable idea of what is required. For example, for lumber, use basic dimensions such as 2x4 or 4x4.

The materials needed for my Eagle Scout Project are:

The Fitness equipment
Cement
Mulch/rubber mulch
Plastic wall barriers
Hardware
Weed barrier ground cloth

Supplies

Supplies are things you use up, such as food and refreshments, gasoline, masking tape, tarps, safety supplies and garbage bags.

What types of supplies, if any, will you need? You do not need a detailed list or exact quantities, but you must show you have a reasonable idea of what is required.

Garbage bags
Pizza
Water bottles
Soda
Gas for transportation
5 gallon buckets

Preliminary Cost Estimate

You do not need exact costs yet. Reviewers will just want to see if you can reasonably expect to raise enough money to cover an initial estimate of expenses. Include the value of donated materials, supplies, tools, and other items. It is not necessary to include the value of tools or other items that will be loaned at no cost. Note that if your project requires a fundraising application, you do not need to submit it with your proposal.

Enter your estimated expenses below
(include sales tax if applicable)

Materials:	<input type="text" value="\$3,690"/>
Supplies:	<input type="text" value="\$1,200"/>
Tools:	<input type="text"/>
Other:	<input type="text" value="\$476.78"/>
Total Costs:	<input type="text" value="\$5,367"/>

Fundraising: Explain how you will raise the money to pay for the total costs. If you intend to seek donations of actual materials, supplies, etc., then explain how you plan to do that, too.

I will raise money by doing a Go Fund Me, this will allow everyone around the world to see if they would like to fund the project. Go Fund Me only takes 2.9% + 0.30 cents from each donation. I will also go around to local stores like Walmart to see if they are willing to fund the project; if I am able to have my city council to give me a letter saying that the project is in motion, this will help the request out even more.

Project Phases

Think of your project in terms of phases, and list what they might be. The first may be to prepare your project plan. Other phases might include fundraising, preparation, execution and reporting. You may have as many phases as you want, but it is not necessary to become overly complicated; brief, one line descriptions are sufficient. If you have more than 10 phases, attach a separate page with your continued phase list.

1 Troop approval
2 City Council approval
3 Fundraising
4 Equipment purchasing
5 Installation scheduling
6 Installation
7 Project Report
8
9
10

Logistics

How will you handle transportation of materials, supplies, tools, and helpers?

I will have my parents, others adults, and Mr. Chance to bring materials, supplies, tools, and helpers by car or truck.

Safety Issues

The Guide to Safe Scouting is an important resource in considering safety issues.

Describe the hazards and safety concerns of which you and your helpers should be aware.

Read the "[Age Guidelines for Tool Usage](#)" at Scouting.org

People will need to be careful with the cement, so no one gets any on them. Holes will be in the area to put the equipment in. Water will be needed to keep people hydrated. Equipment like shovels will be used in the area to dig. The fitness equipment will be carried, so making sure dropping or hitting someone with the fitness equipment.

Project Planning

You do not have to list every step, but it must be enough to show you have a reasonable idea of how to prepare your plan.

List some action steps you will take to prepare your project plan. For example, "Complete a more detailed set of drawings."

My first step is to have this approved by the Eagleville City Council so I can start with their permission. The second step is to have a detailed picture of the area with everything is going to go, where the fitness equipment is specifically is going to go, and how deep the holes for the fitness equipment needs to be. My third step is to have exact dates ready for this so everyone knows when this is happening, and to make sure that the project is not done on a day where it will not rain.

Tools

Include tools, and also equipment, that will be borrowed, rented, or purchased.

What tools or equipment, if any, will you need? You do not need a detailed list, but you must show you have a reasonable idea of what is required.

Digging holes: Shovels and post hole diggers

Mixing Cement: Wheelbarrows, Extension Cord, Mixing Paddle, and Drill

Build Equipment: Wrenches, Ratchets, Sockets, and Screwdrivers

Measuring Hole depth: Measuring tape

Protection: Safety glasses

Cutting ground cloth: Knife/scissors

Hammer down stakes for plastic barrier: Hammer

Even out mulch: Rakes

Other Needs

Items that don't fit the above categories; for example, parking or postage, or services such as printing or pouring concrete, etc..

What other needs do you think you might encounter?

Funding for the project

Friends and Family to support spreading the word about the fundraising

Installation Support from the manufacturer or approved installer

Transportation for people helping move materials and supplies

Permits and Permissions

Note that property owners should obtain and pay for permits.

Will permissions or permits (such as building permits) be required for your project? Who will obtain them? How long will it take?

City Approval

Item 11b Resolution 2026-005 Petition for Annexation

RESOLUTION 2026-005

A RESOLUTION CALLING FOR A PUBLIC HEARING ON THE PROPOSED ANNEXATION OF TERRITORY INTO THE CITY OF EAGLEVILLE BY OWNER CONSENT AND APPROVING A PLAN OF SERVICES

(Parcel #**120 02300**, 256.6 Approximate Acres Located on the Southeast Corner of John Windrow Road and US 41-A, Eagleville, Tennessee 37060)

WHEREAS, the City of Eagleville, having been petitioned by interested persons, proposes the extension of its corporate limits by the annexation of certain territory adjoining its existing boundaries and within its urban growth boundaries by owner consent; and

WHEREAS, a plan of services for the territory proposed for annexation by owner consent has been reviewed by the Eagleville Planning Commission; and

WHEREAS, the governing body desires to conduct a public hearing on the proposed annexation and plan of services;

NOW THEREFORE BE IT RESOLVED by the City of Eagleville, Tennessee as follows:

- A. That a public hearing is hereby scheduled for 7:00 p.m. on July 23, 2026 at Eagleville City Hall, 108 S. Main Street, on the proposed annexation of territory by owner consent, and Plan of Services, to wit:

Parcel #**120 02300**, 256.6 Approximate Acres Located on the Southeast Corner of John Windrow Road and US 41-A, Eagleville, Tennessee 37060

- B. That a copy of this resolution, describing the territory proposed for annexation by owner consent, along with the plan of services, shall be promptly sent to the last known address(es) listed in the office of the Rutherford County Property Assessor for each property owner of record within the territory proposed for annexation, with such being sent by first class mail and mailed no later than twenty-one (21) calendar days prior to the scheduled date of the hearing on the proposed annexation.

- C. That a copy of this resolution shall also be published by posting copies of it in at least three (3) public places in the territory proposed for annexation and in a like number of public places in the City of Eagleville, and by publishing notice of the resolution at or about the same time in the Daily News Journal, a newspaper of general circulation in such territory and the City of Eagleville.

D. That notice of the time, place and purpose of a public hearing on the proposed annexation by owner consent and the plan of services shall be published in a newspaper of general circulation in the City of Eagleville not less than twenty-one (21) days before the hearing, which notice included the locations of a minimum of three (3) copies of the plan of services for public inspection during all business hours from the date of notice until the public hearing.

E. That written notice of the proposed annexation shall be sent to the affected school system as soon as possible, but in no event less than thirty (30) days before the public hearing.

WHEREUPON, the Mayor declared the Resolution adopted, affixed a signature and the date thereto, and directed that the same be recorded.

Chad Leeman, Mayor Date

Christina Rivas, City Recorder Date

Approved as to Form this ____ day of _____, 2026

J. Stephen Aymett, Jr, City Attorney

**ATTACHMENT A
OF RESOLUTION 2026-006**

**A PLAN OF SERVICES FOR THE ANNEXATION OF PARCEL 120 02300, LOCATED
ON THE SOUTHEAST CORNER OF JOHN WINDROW ROAD AND US 41A,
EAGLEVILLE, TENNESSEE, APPROXIMATELY 256.6 ACRES**

The Tennessee Code Annotated § 6-51-102 requires that a plan of services be adopted by the municipal governing body prior to passage of an annexation ordinance; and the area proposed for annexation into the City is within the City's Urban Growth Boundary, as required by law, and is described as follows:

ANNEXATION OF PROPERTY

This annexation consists of the following property: Parcel 120 02300, located at the southeast corner of John Windrow Road and Highway 41A, approximately 256.6 acres

Section 1. Pursuant to the provisions of T.C.A. § 6-51-102, there is hereby adopted, for the area bounded as described above, the following plan of services:

A. Police

1. Patrol, response to calls, and other routine police services, using present personnel and equipment, will be provided to this property on the effective date of annexation in the same manner as provided to existing residents of Eagleville.

B. Fire Services

1. Fire protection by the present personnel and equipment of the fire department, within the limitations of available water and distances from fire stations, will be provided to this property on the effective date of annexation in the same manner as provided to existing residents of Eagleville.

C. Water

1. Water is provided by the local utility company, Consolidated Utility District, with rates and conditions of approval at the discretion of the utility company.
2. Water for fire protection will be provided by the local utility company, Consolidated Utility District, with rates and conditions of approval at the discretion of the utility company.

D. Wastewater

Wastewater will be either by Septic on each parcel, or by an agreement between the property owner and the City of Eagleville for a STEP system.

E. Garbage Collection

The City does not currently offer garbage collection to its residents. There exists a county facility where trash can be taken. The property will be afforded all rights as the current Eagleville Citizens.

F. Streets

1. The City will commence maintenance any new roadway as part of the annexation upon successful completion and acceptance thereof.
2. Traffic signals, traffic signs, street markings, and other traffic control devices will be installed as the need is established by appropriate study and traffic engineering standards. Initial street signals, signage, street markings and other traffic control devices will be installed by the developer of any new subdivision.

G. Schools

Area to be annexed will remain as part of the Rutherford County Schools System.

H. Inspections and Code Enforcement

Building and Municipal Code Enforcement will be provided by the City of Eagleville or through its contracted provider.

I. Zoning

The property will be assigned a zoning classification of R-1/PRD (Planned Residential District).

J. Street Lighting

1. As necessary, when lighting is needed, the City will work with the property owner to support adequate and necessary lighting of streets or other areas. Initial installation of any new subdivision will be at the cost of the developer.

K. Recreation

1. Any residents of this annexed parcel will have all rights to any public parks afforded to any existing resident.

Item 11c Ordinance 2026-001 Zoning Classifications for Parcel 120
04600

ORDINANCE 2026-001

AN ORDINANCE ASSIGNING A ZONING CLASSIFICATION AND CREATING SPECIFIC CRITERIA IN ANTICIPATION OF ANNEXATION OF PROPERTY KNOWN AS PARCEL 120 04600, APROXIMATELY 98.21 ACRES, PROPERTY IMMEDIATELY SOUTH OF COLLEGE GROVE ROAD AND WEST OF HIGHWAY 41A, CURRENTLY OWNED BY SALEM CREEK PARTNERSHIP

Whereas, Section 5.080 of the Eagleville Zoning Ordinance allows for Planned Developments and Section 5.081 specifically addresses Planned Residential Developments; and

Whereas, the Eagleville Planning Commission has reviewed criteria for Parcel 120 04600 and recommends the property be annexed and zoned R-1 PRD with following as requirements in addition to the requirements of 5.080 and 5.081 of the Eagleville Zoning Ordinance for any development on this property; and

Whereas, the Eagleville City Council desires to accept the recommendation of the Eagleville Planning Commission by setting specific criteria in addition to the requirements of Eagleville Zoning Ordinance Sections 5.080 and 5.080 (and other relevant criteria in the Zoning Ordinance) for Parcel 120 04600 owned by Salem Creek Partnership, or any future Development located at this parcel as a binding agreement for Annexation;

NOW THEREFORE, BE IT ORDAINED by the City of Eagleville, Tennessee City Council that the Parcel 120 04600 being annexed by the City of Eagleville be zoned R-1/PRD and the following criteria shall be applied and required when reviewing any subdivision or development submitted for **Parcel 120 04600**.

General Requirements

1. All homes shall be a minimum of 3 bedrooms with a maximum number of 5 bedrooms per house based on STEP capacity.
2. Entrances off Highway 41A will have new entrance signage consisting of masonry or wood, and may have some metal materials. The signage will be anchored by landscaping.
3. Solid waste collection will be handled by a private company to be paid by the HOA or resident.
4. If mail service is not provided by individual mail boxes, mail service will be provided via a Centralized Cluster Box Unit with a roof structure, that is to be approved by the USPS and maintained by the HOA. The Centralized mail kiosk for the development must be

completed and operational prior to any homes receiving their certificate of occupancy. If individual mailboxes are allowed by the USPS, they shall be decorative in nature with the design consistent throughout the neighborhood, and approved by the Planning Commission.

5. Parking areas on common open space lots, including mailbox area, shall be private and maintained by the HOA, and shall be paved.
6. Each home shall be on its own lot of record and sold fee simple.
7. Before any individual lots are sold outside of Salem Creek Partnership, or any house is constructed, there must be access to a STEP system. The first phase will include all roadway improvements proposed for the lots, as well as access to the STEP System via a City approved access.
8. Any STEP system constructed must be approved by the City of Eagleville, and then turn over to the City to maintain and receive all revenue billing from the treatment of the STEP system.
9. All amenities and open spaces shall be constructed within the phase they are shown and must be operational prior to the recording of the final section's plat.

Development Standards

1. Parking for the residential units will comply with the City of Eagleville requirements, with a minimum of each lot having at least 4 paved parking spaces per lot (outside of garage), with no more than 2 of the outdoor spots being in tandem.
2. Each home shall have a minimum two car side entry (non-street facing) garage with decorative garage doors. In cases of a corner lot, it is understood that one side may have a garage facing one of the streets. Garages must be proven to the Planning Commission that the size does indeed hold two average size vehicles. Homes with two car garages are also permitted to have a one bay detached or attached garage that is permitted to face the street. The street facing garage shall have a decorative garage door that matches the main side entry garage doors, and the architecture and materials shall be consistent with the house. The secondary garage must be approved by the HOA if not submitted with the original permit.
3. All lots shall have concrete driveways wide enough for 2 vehicles, with a minimum width of 16-feet and a minimum depth of 35-feet.
4. Only in-ground pools shall be permitted with fencing to meet Development Standards. Pools must meet requirements of the City's Zoning Ordinance pertaining to setbacks.

5. All HVAC units shall be screened from public R.O.W.s with landscaping. HVAC units shall be placed at the side or rear of each residence.
6. Private lots with fences shall only use Estate Style iron or aluminum fencing. Fencing on lots shall only be allowed in the side and rear yards. Corner lots may have a fence on the street side of which the house does not face and shall not exceed into the required front setback.
7. All fencing in the amenity areas and open spaces shall be consistent with fencing allowed in the subdivision, or as otherwise approved by the Planning Commission.
8. Sidewalks, compliant with ADA and City of Eagleville standards, shall be on both sides of the streets internal to the subdivision.

Streets and Infrastructure

1. Decorative streetlights shall be provided along all roadways to add character and continuity to the neighborhood. Adequate lighting for safety will be designed to meet Middle Tennessee Electric (MTE) standards at a minimum for light poles along public streets. Electric billing for lighting, mail kiosks, entrance features, irrigation and other supplemental amenities shall be paid by the HOA.
2. Electric Service will be provided by Middle Tennessee Electric.
3. All electric, communications line extensions and other utilities constructed to provide service to the development shall be underground throughout the entire subdivision.
4. Street signs and traffic signs will be “decorative” and approved by the Planning Commission.
5. The HOA will maintain all common areas.
6. Water service will be provided by Consolidated Utility District. The developer will be responsible for extending the waterline into the site for domestic and fire protection. Water service (availability and pressure) must be approved by the City Planner and/or Eagleville Fire Department. Hydrants are required that meet CUD standards.
7. Sanitary sewer services will be provided by CUD or another Eagleville-Approved Wastewater Company via an on-site STEP System. The developer is responsible for the installation, and upon its completion, ownership shall be turned over to the City of Eagleville to own and maintain.
8. All streets will be public rights of way, and built with rollover integral curb and gutter, and built to City required standards.

9. Any portion of the property that lies within a 100-year Floodplain per FEMA Flood Maps shall have an established BFE by developer's engineer and shall be in accordance with TDEC and the Corps of Engineers requirements, along with the City of Eagleville's flood plain ordinance.
10. Prior to construction, a complete and thorough design of the stormwater management system and facilities will be completed.

Architecture

1. Building heights shall not exceed 35 feet in height.
2. Homes will be 2,500 square feet or greater, and have 1, 2 (or 3) stories.
3. Any single-story homes shall have architectural elements which allow the home to blend into the larger homes with peaked roofs, dormers or other elements adding height to the single-story homes.
4. All the homes will have eaves.
5. All homes will have a concrete patio area at the rear of the home.
6. All homes will be located on individual lots of record.
7. Accessory Buildings will complement the house with the same or similar materials. No metal buildings will be permitted. Accessory Buildings must be approved by the HOA if not submitted with the original building permit.
8. Houses and other buildings will be comprised of alternating home styles, materials and colors but that are complimentary to each other.
9. Building Materials – All Elevations: Only allowed to have Masonry (Brick, Stone, Cement Board Siding) and Cement Board Siding in the Dormers/Gables. Vinyl Only Permitted in Trim & Soffit Areas (10% maximum per side and for whole building).

Bulk Requirements

1. Minimum lot size 2 acres or 87,120 square feet.
2. Minimum lot frontage – 90 feet (except lots located within the arc of the cul de sac may be reduced to 45 feet)
3. Minimum lot width – 90 feet (except lots located within the arc of the cul de sac may be reduced to 45 feet)

4. Minimum Front Setback – 60 feet – for all structures (except pools – see Eagleville Zoning Ordinance.
5. Minimum Front Setback for corner lots – Both 60 and 60 feet - for all structures.
6. Minimum Side Setback – 30 feet for all structures (except pools – see Eagleville Zoning Ordinance.
7. Minimum Rear Setback – 25 feet - for all structures (except pools – see Eagleville Zoning Ordinance.

Landscaping Characteristics

1. On common open space lots, a minimum of 10-feet of landscape area shall be provided between a parking area and all adjacent property lines.
2. On common open space lots, parking areas shall be screened from public rights-of-way by use of landscaping and/or berms.
3. The frontage along Highway 41A screened (berm, trees, etc) as approved by the Planning Commission. The purpose of this screening is mostly to avoid views to rear and side yards. Any landscaping provided along Highway 41A shall be designed to not impede the visibility of vehicles entering or exiting the site onto Highway 41A.
4. All above ground HVAC units shall be screened from public R.O.W.'s with landscaping or approved fencing.
5. No utility panels shall be mounted on the front elevation of any home. In cases of two frontages, when no other option is available, the panel may be mounted on the side where the garage is located.
6. On corner lots, builders shall install a minimum of a 3-foot-wide landscape strip along all sides that face/about a public R.O.W. On lots internal to the street block, builders shall install a minimum of a 3-foot-wide landscape strip at the base of the homes that front onto/about a public R.O.W.
7. Landscaping will be in conformance with the City of Eagleville's landscaping ordinance.
8. On corner lots, builders shall install sod at least in all yards that face/about a (proposed) public R.O.W.'s to the back of curb along those streets. On lots internal to the street block, builders shall install sod at least in the front yard to the back of curb along that street the house front onto.
9. Builders shall install one (1) front yard canopy tree with a minimum of 1.5 caliper inches for each lot. Species of tree to be coordinated with Planning Commission.

BE IT ENACTED that this ordinance shall take effect 15-days from and after its final passage, the public welfare requiring it.

Approved:

Chad Leeman, Mayor

ATTEST:

Christina Rivas, City Recorder

Passed First Reading:

Passed Second Reading:

Public Hearing Date:

APPROVED AS TO FORM:

Stephen Aymett, City Attorney